



General description

The Skum Water Actuated Foam Valve (WAFV) consists of a ball valve and an approved, corrosion resistant actuator; the valve operates by water pressure only, i.e. mains water pressure supply on a bladder tank system or from the water motor alarm port in a fire sprinkler system.

The WAFV valve body is made from 316 stainless steel and the actuator has an approved, corrosion resistant manufacture.

The actuator will open the valve when supplied with water pressure of 2-16 bar and must be manually reset. The actuator is fitted with a manual override feature.

Application description

The WAFV is primarily used in bladder tank foam systems and is installed in the foam concentrate line just before the proportioner. When the foam system is operated the increased water pressure opens the WAFV and discharges foam concentrate to the proportioner. WAFV valves are also used in foam pump balanced pressure proportioning systems, or in non-pressurised tank systems where the proportioner is located at a lower level than the tank. In such applications the WAFV prevents foam leakage or foam siphoning into the water line. WAFV's may be used with all types of foam concentrates.

Approvals

- Det Norske Veritas (DNV)
- Germanischer Lloyd (GL)
- Lloyd's Register of Shipping (LRS)

WAFV 80 WE



Prepiped bladder tank foam system
Incl. WAFV



by Tyco Fire Suppression & Building Products

www.skum.com

Technical changes reserved without notice
Copyright © 2009 Tyco Fire Suppression & Building Products

TYLENSKUM27 04/10



Connections

- Foam: Screw threaded BSP or weld end (WE)
- Water actuating line: Screw threaded BSP 1/4", marked A

WAFV Reset

The actuator must be manually reset through the following procedures:

- The resetting lever is attached to the actuator, and can easily be mounted on the operating shaft
- Check that the pressure from the water actuating line is relieved
- Manually operate the lever in order to close the valve

Product Features

- Designed to meet the requirements of FM and VdS
- Stainless Steel foam concentrate ball valve
- Standard part in a Skum Pre-piped bladder tank system

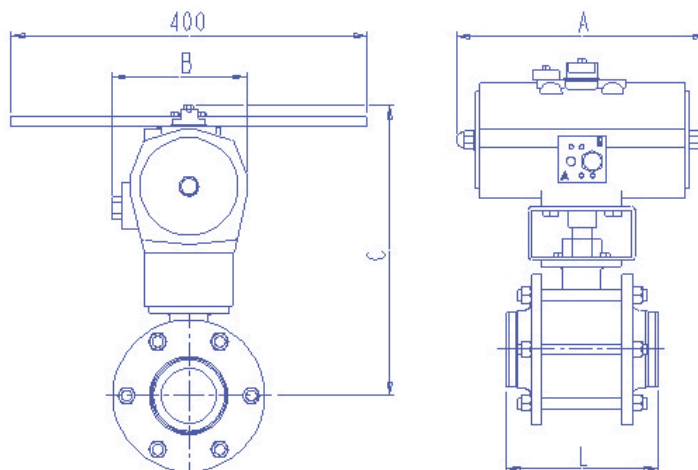

Order information

Description	Part No.
WAFV-20	BSP 127802326
WAFV-20	WE 127802322
WAFV-40	BSP 127804222
WAFV-40	WE 127804218
WAFV-50	BSP 127805222
WAFV-50	WE 127805218
WAFV-80	WE 127808221

Performance Data	
WAFV-20, WAFV-40, WAFV-50, WAFV-80	
Working pressure	Max. 16 bar / 232 psi
Opening pressure	Min. 2 bar / 29 psi

WE = Weld end

Performance Data

Type	Connection		Dimensions				Weight		Materials	
			A	B	C	L	kg	lbs	Valve	Actuator
	Actuator	Valve	mm	mm	mm	mm				
WAFV-20	BSPT 1/4" female thread	20mm / 3/4" WE or BSPP female thread	159	95	162	73	2,1	4,6	Stainless steel	Aluminium
WAFV-40	BSPT 1/4" female thread	40mm / 1 1/2" WE or BSPP female thread	180	108	195	110	4,6	10,1	Stainless steel	Aluminium
WAFV-50	BSPT 1/4" female thread	50mm / 2" WE or BSPP female thread	180	108	199	126	5,6	12,3	Stainless steel	Aluminium
WAFV-80	BSPT 1/4" female thread	80mm / 3" WE BSPP female thread	283	149	337	170	17,8	39,2	Stainless steel	Aluminium

1 bar = 0,1 MPa=14,5 psi



by Tyco Fire Suppression & Building Products

www.skum.com

Technical changes reserved without notice
Copyright © 2009 Tyco Fire Suppression & Building Products

TYLENSKUM27 04/10