



### General description

An accurate proportioner for foam concentrate, irrespective of flow and pressure variations is vital for the correct performance of a foam system.

The new Skum PPW proportioners provide more accurate proportioning, a wider flow range with a lower line pressure drop than the original units.

### Application description

This type of proportioner is used in foam pump and closed head sprinkler systems. The PPW series is designed for monitor and deluge systems or where large flow variations occur.

### Product features

- Designed to meet the requirements of EN 13565-1 and NFPA 16 Ch 4
- Factory set to deliver accurate foam proportioning up to 6%
- Corrosion resistant design
- Maximum/minimum flow rate ratio of 120:1
- Maintenance free construction
- Compact design
- Foam proportioning as low as 100 l/min
- Wafer type water connections

### Connections

- Water: wafer mounted between flanges, see table
- Foam: flanged to fit DIN PN 16 or ANSI 150 lbs



PPW-200

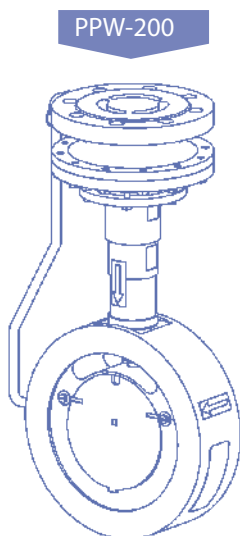
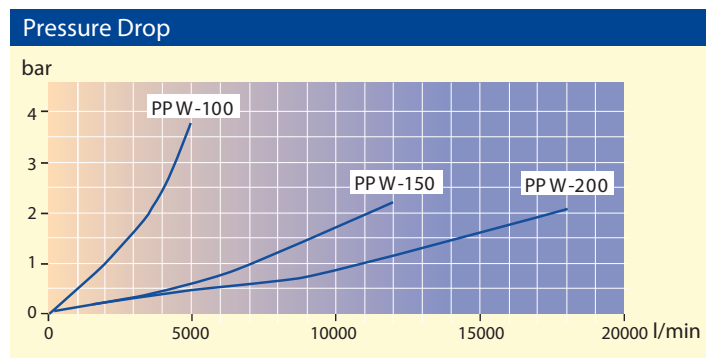

PPW-200

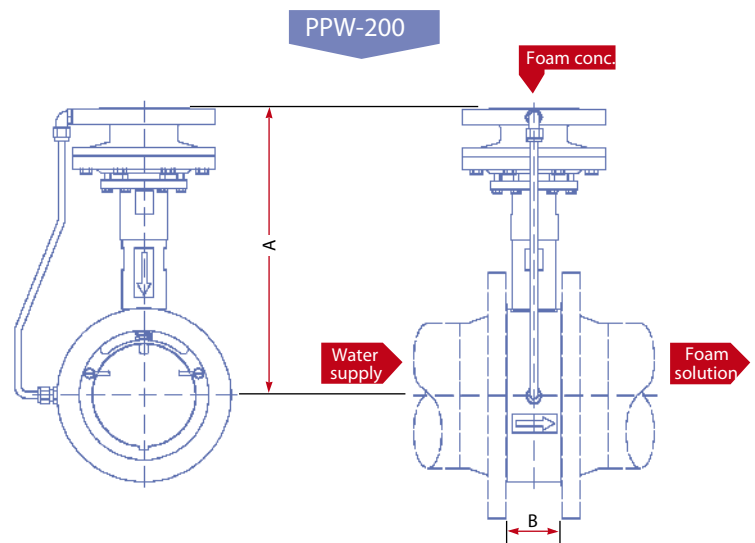

PPW-200





### Operation

Fully automatic foam proportioning within the flow and pressure range. The foam inlet pressure must be at least 1 bar higher than the water pressure.

### Installation

A minimum of five diameters (D) of straight pipe is required in water line before entering the proportioner and three diameters (D) after the proportioner.

### Listings and approvals

- Tested according to and complying with EN 13565-1
- Russian State Fire Academy
- Det Norske Veritas (DNV)
- Russian Maritime Register of Shipping (RMRS)
- Bureau Veritas (BV)

### Order information - please specify:

1. Part Number
2. Size
3. Foam proportioning %
4. Foam type

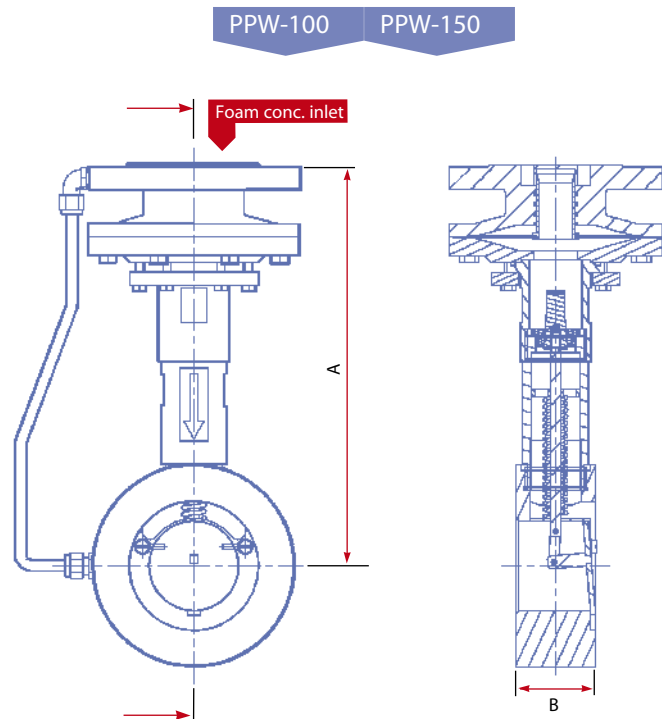

Description	Part No.	Description	Part No.
PPW-100 DIN/ANSI 3% AFFF	123510103A	PPW-200 DIN 3% AFFF	123520114A
PPW-100 DIN/ANSI 3% AR	123510103C	PPW-200 DIN 3% AR	123520114C
PPW-100 DIN/ANSI 2%	123510103E	PPW-200 DIN 2%	123520114E
PPW-100 DIN/ANSI 1%	123510103B	PPW-200 DIN 1%	123520114B
PPW-150 DIN/ANSI 3% AFFF	123515107A	PPW-200 ANSI 3% AFFF	123520215A
PPW-150 DIN/ANSI 3% AR	123515107C	PPW-200 ANSI 3% AR	123520215C
PPW-150 DIN/ANSI 2%	123515107E	PPW-200 ANSI 2%	123520215E
PPW-150 DIN/ANSI 1%	123515107B	PPW-200 ANSI 1%	123520215B

Matrix for Foam Concentrate Mix				
AFFF/P/FP 3%	AFFF/AR 1%	AR AFFF 3%	HotFoam 2%	AFFF/AR 6%
A	B	C	E	J

Performance Data									
Type	Connection		Capacity				Weight		Material
			Min.		Max.**				
	Foam*	Water	l/min	USGPM	l/min	USGPM	kg	lbs	
PPW-100	50 / 2"	100 / 4"	100	26	5,000	1,321	19	42	Bronze (Cu88Sn12)
PPW-150	50 / 2"	150 / 6"	100	26	12,000	3,170	22	48	Bronze (Cu88Sn12)
PPW-200	50 / 2"	200 / 8"	175	46	18,000	4,756	44	97	Bronze (Cu88Sn12)

1 bar = 0,1 MPa = 14,5 psi      \* Flanges to fit DINPN 16 or ANSI 150 lbs  
\*\* Maximum flow at 6% is reduced

Dimensions PPW		
Type	A mm	B mm
PPW-100	312	62
PPW-150	333	62
PPW-200	393	82

