



General description

The around the pump inductor is a foam concentrate proportioning unit designed for connection in a by-pass between the pressure and suction side of the fire water pump. This system diverts a small part of the feed water flow through the PI, with a negligible effect on the fire water line pressure.

Commonly used in marine applications, around the pump inductors are also used on specialised foam trucks or fixed systems where a dedicated water pump is available.

Product features

- Manufactured using corrosion resistant materials
- Factory calibrated flow/pressure settings
- Can be set to selected flows anywhere within the PI range
- Negligible effect on main water line pressure
- Cost effective, value added solution
- High quality, high reliability
- Can be installed horizontally or vertically
- Integrated suction check valve and regulating valve
- PI series ranges from 100 to 22500 l/min system capacity and 1 to 680 l/min foam liquid suction capacity

Connections

- Water / foam inlet: flanged to fit DIN PN16 or ANSI 150lbs or screw threaded BSP

Order information - please specify:

1. Part number
2. Foam induction

Description	Part No.	Description	Part No.
PI-25	122102105	PI-100 DIN	122210123
PI-65 DIN	122106106	PI-100 ANSI	122210172
PI-65 ANSI	122106203		

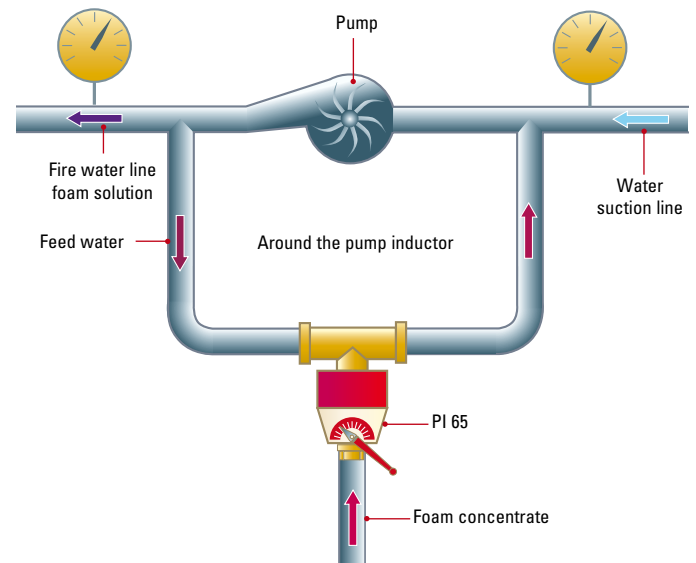

Performance Data

PI-25						PI-65						PI-100					
Feed water capacity				Max. induction capacity		Feed water capacity				Max. induction capacity		Feed water capacity				Max. induction capacity	
bar	psi	l/min	USGPM	l/min	USGPM	bar	psi	l/min	USGPM	l/min	USGPM	bar	psi	l/min	USGPM	l/min	USGPM
6	87	76	20	65	17	6	87	230	61	255	67	6	87	620	164	680	180
8	116	88	23	65	17	8	116	267	71	255	67	8	116	720	190	680	180
10	145	98	26	65	17	10	145	300	79	255	67	10	145	800	212	680	180
12	174	107	28	65	17	12	174	327	86	255	67	12	174	880	233	680	180



by Tyco Fire Suppression & Building Products

www.skum.com

Technical changes reserved without notice
Copyright © 2009 Tyco Fire Suppression & Building Products

TYLENSKUM16 05/10



PI-25

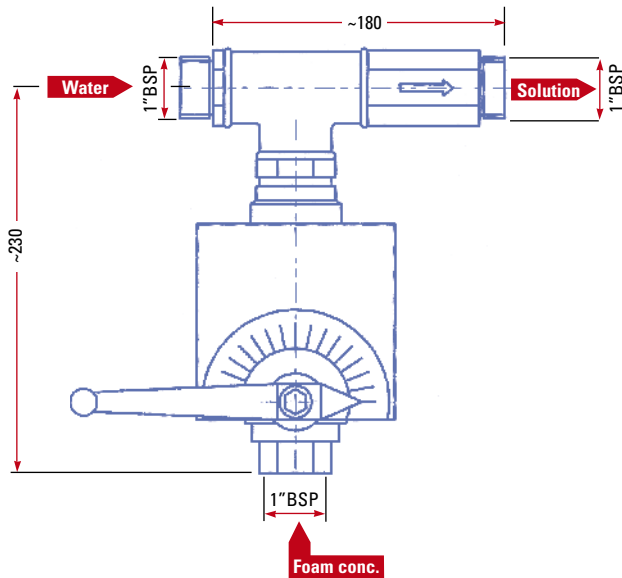

PI-65

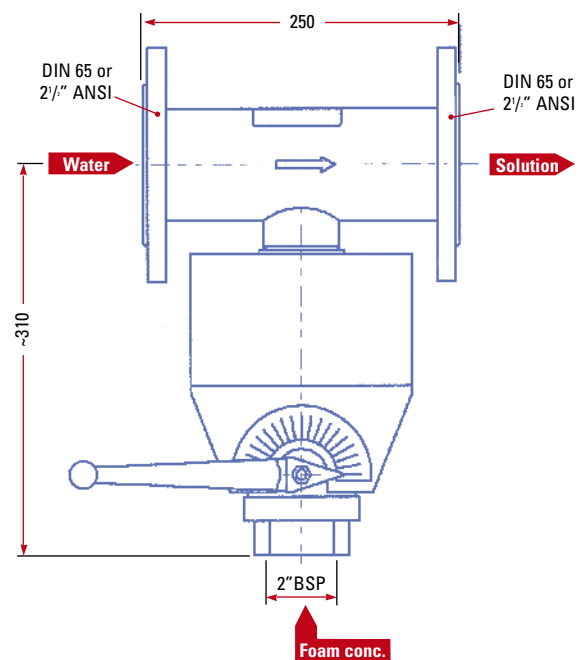

Performance Data

PI-25

Max. counter pressure	0,5 bar / 7,2 psi
Max. working pressure	16 bar / 232 psi
Connection: Water	Male 1" BSP
Foam concentrate	Female 1" BSP
Weight	3 kg / 6,6 lbs
Material: Inductor	Brass
Foam conc. valve	Brass

PI-65

Max. counter pressure	0,5 bar / 7,2 psi
Max. working pressure	16 bar / 232 psi
Connection: Water	65 DIN PN 16 or 2 1/2" ANSI 150 lbs
Foam concentrate	Female 2" BSP or Male 2" NPT
Weight	14 kg / 31 lbs
Material: Body	Stainless steel
Nozzle, diffuser	Polypropylene
Valve, check valve	Brass

PI-100

Max. counter pressure	0,5 bar / 7,2 psi
Max. working pressure	16 bar / 232 psi
Connection: Water	100 DIN PN 16 or 4" ANSI 150 lbs
Foam concentrate	80 DIN PN 16 or 3" ANSI 150 lbs
Weight	45 kg / 99 lbs
Material: Body	Stainless steel
Nozzle, diffuser	Polypropylene
Valve, check valve	Stainless steel
Flange	Galvanized steel

1 bar = 0,1 MPa = 14,5 psi

PI-100

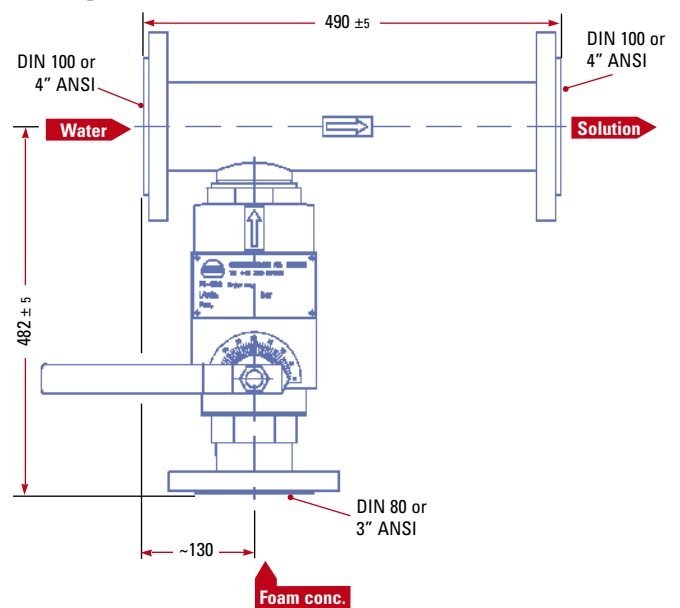

by Tyco Fire Suppression & Building Products

www.skum.com

Technical changes reserved without notice
Copyright © 2009 Tyco Fire Suppression & Building Products

TYLENSKUM16 05/10