

Low Expansion Foam Sprinkler SPR-6

General Description

The SPR-6 low expansion foam sprinkler is designed for use in a deluge type foam sprinkler system. It is primarily intended for use with AFFF foam concentrates but other types may also be used.

The sprinkler has a compact and rigid construction and can be used both inside and outside; it can be mounted horizontally or vertically.

The SPR-6 is fed from a separate foam proportioner.

Product Features

- Stainless steel body and bronze nozzle
- Low weight
- Large area coverage
- Suitable for indoor and outdoor use
- Capacity 60 l/min at 2.5 bar
- Foam expansion to 12:1
- K-factor 38

Connections

- Foam inlet: threaded to BSP 3/4" male

Order Information

Part No.	Description
108102107	SPR-6

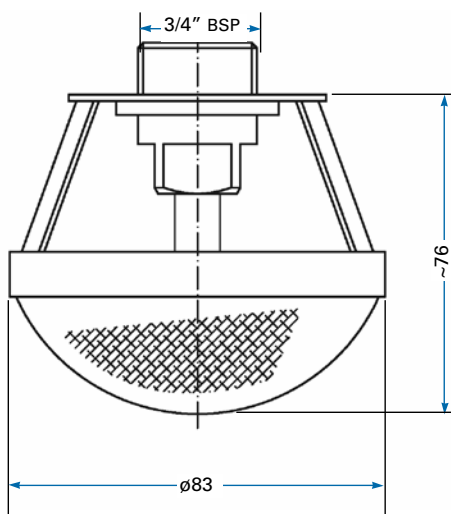

Specification

SPR-6

Flow at inlet 2.5 bar	60 l/min	
Flow can be calculated as	$Q = \sqrt{Px38}$	
Foam expansion factor, approx.	12:1*	
Connection	Male 3/4" BSP	
Material:	Basket	Stainless steel
	Nozzel	Bronze
Weight	0.15 kg / 0.33 lbs	

*Depending on foam concentrate type
1 bar = 0.1 MPa = 14.5 psi

Spray Radius

