

Mini Fomax Foam Generator

General Description

Although smaller than conventional high expansion foam generators, the new light weight version of the Mini Fomax offers similar expansion and foam output to its bigger brother. It is suited to all normal high expansion applications and powered by a single water nozzle driving a bronze pelton wheel. Simply connect to a supply of synthetic foam compound, and a pressurised water supply.

The Mini Fomax is ideally suited for all total flood applications such as warehouses, ship holds, engine rooms, machinery spaces, electric cable ducting, chemical processing and refining plants and mines.

The Mini Fomax SI version is available with a built-in foam inducing system or a standard unit can be run in conjunction with a 200 l/min inductor, such as the IND 50.

The Mini Fomax SE version is a portable smoke extraction unit with a 7.5m length of smoke extraction ducting attached by quick release strap which is suitable for smoke extraction in hazardous areas that need an intrinsically safe operation.

Product Features

- Easily portable
- Uniquely small size
- Light weight
- One man operation
- Optional built-in foam inducing system
- Excellent expansion and foam output performance
- Smoke extractor option



Typical Performance Figures

Pressure	Total water flow l/min	Foam production m ³ /min	Foam expansion
■ 5.0 bar	225	90	400:1
■ 5.0 bar	250	117	470:1
■ 5.0 bar	270	135	500:1

Pressures are measured at the water inlet. Performance may be subject to slight variation with changes in ambient temperature and foam compound composition.

Technical Data

- Construction Red, high impact durable polyethylene body; all pipework and fittings in corrosion resistant materials. The pelton wheel installation is maintenance free.
- Expendable ducting The generator is designed to use expendable tubing for ducting foam. Attaching the tubing is a simple, quick operation.
- Smoke extractor version The Mini Fomax is ideally suited for use as a smoke extractor. A 7.5m length of smoke extraction ducting can be supplied with the unit for simple connection by quick release strap. Further lengths can be added to achieve the desired length.
- Dimensions and Weight Width: 550mm
Height: 710mm
Depth: 400mm
Weight: 17.5kg

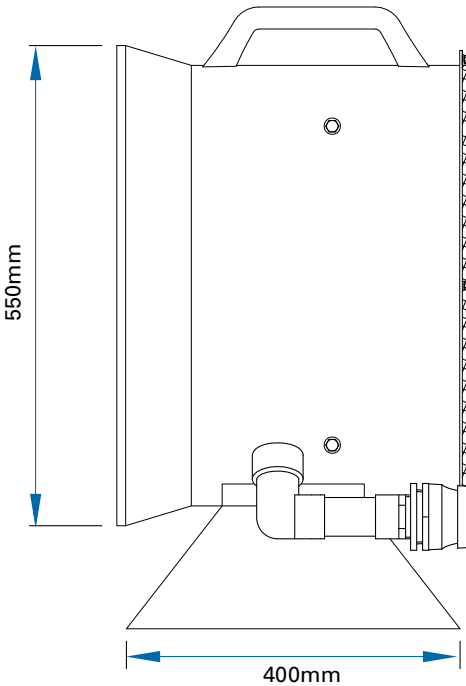
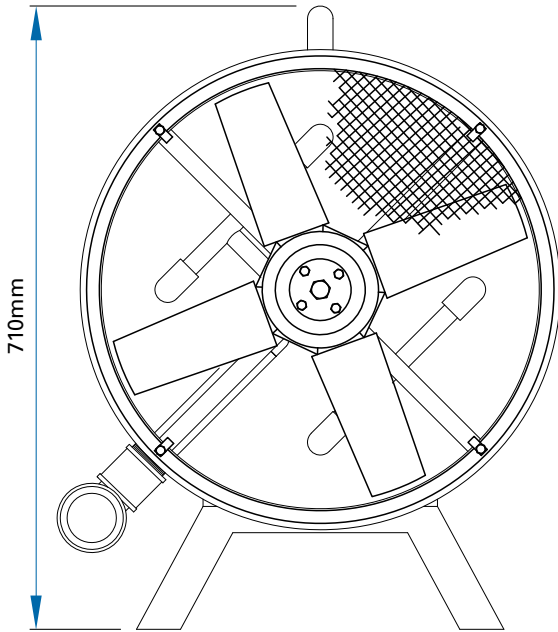

Ordering Information

METEOR T -10 can be supplied in cans, drums, totes or Bulk (contact us for Bulk delivery details).

<u>Part No.</u>	<u>Description</u>
■ F203163C2	20 Litre can
■ F203163C3	20 Litre DIN can
■ F203163C1	25 Litre can
■ F203163D1	200 Litre drum
■ F203163T1	1000 Litre tote
■ F203163B1	Bulk

Recommended Foam

METEOR T -10 can be supplied in cans, drums, totes or Bulk (contact us for Bulk delivery details).

<u>Part No.</u>	<u>Description</u>
■ F203163C2	20 Litre can
■ F203163C3	20 Litre DIN can
■ F203163C1	25 Litre can
■ F203163D1	200 Litre drum
■ F203163T1	1000 Litre tote
■ F203163B1	Bulk