

## Balanced Pressure Proportioner PP MK2

### General Description

The balanced PP proportioner induces foam concentrate into the water feed line. Foam proportioning accuracy is maintained during fluctuations in water flow and pressure.

### Application Description

This type of proportioner is used in foam pump systems. The PP series is designed for monitor and deluge systems.

### Product Features

- Designed to meet the requirements of EN 13565:1 and NFPA 16 Ch 4
- Maintenance free design
- High quality, high reliability
- Manufactured using corrosion resistant design and materials
- Factory set to deliver accurate foam proportioning up to 6%
- Wafer type water connection
- Flanged or screw threaded BSP foam connection

### Connections

- Water: wafer mounted between flanges, see table
- Foam: flanged to fit DIN PN 16 or ANSI 150 lbs or screw-threaded BSP, see table

### Listings and Approvals

- Tested according to and complying with EN 13565:1
- China National Test Centre Approval (TFRI); PP-100; PP-150
- Russian State Fire Academy
- Det Norske Veritas (DNV)
- Russian Maritime Register of Shipping (RMRS)

### Operation

The proportioner will operate automatically when the flow and pressure are within the flow range. The foam pressure must be at least one bar higher than the water pressure through the proportioner. Operates all valves in the system smoothly.



PP-50, PP-80



PP-100, PP-150, PP-200, PP-250



### Installation

A minimum of five diameters (D) of straight pipe is required in the water line before entering the proportioner and three diameters (D) after the proportioner.

### Order Information - Please Specify

1. Part Number
2. Size
3. Foam proportioning %

### Pressure Drop

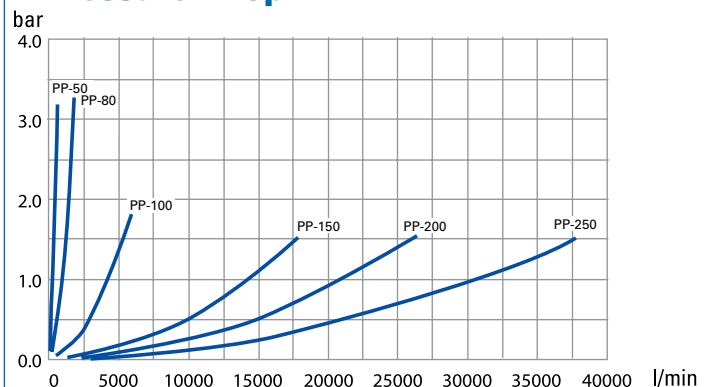

**PP-50 / PP-80**

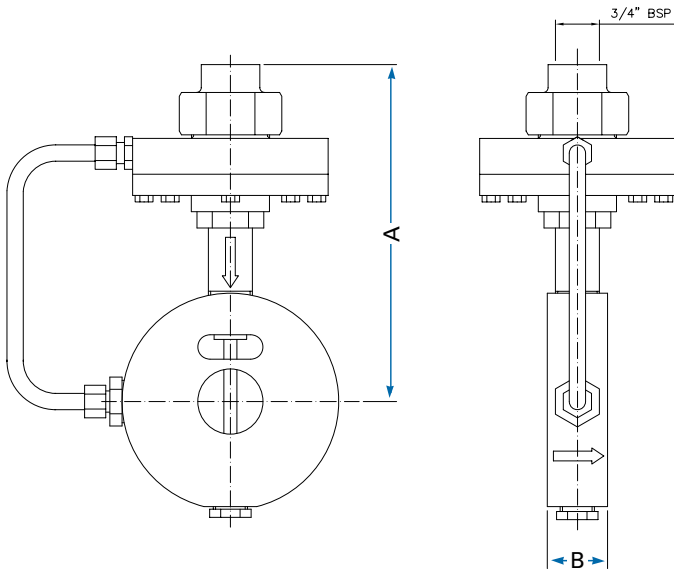

**PP-100 / PP-250**

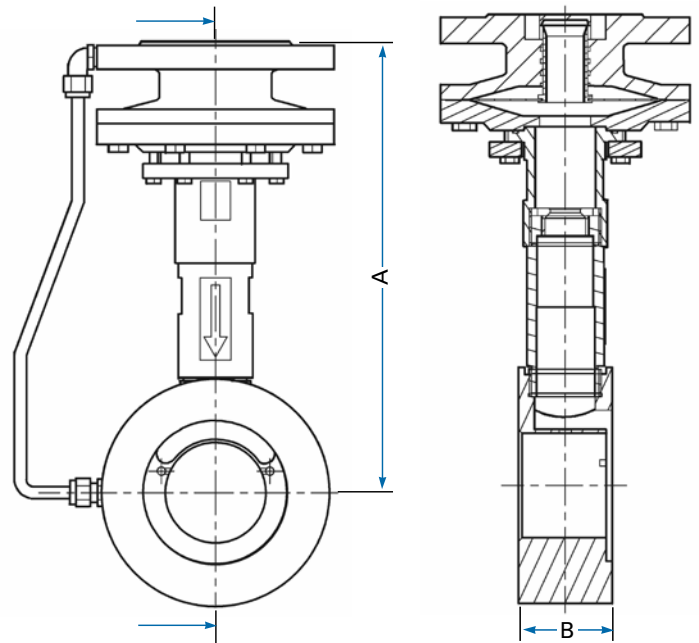

For dimensions A and B please see table below

**PP-200 / PP-250**

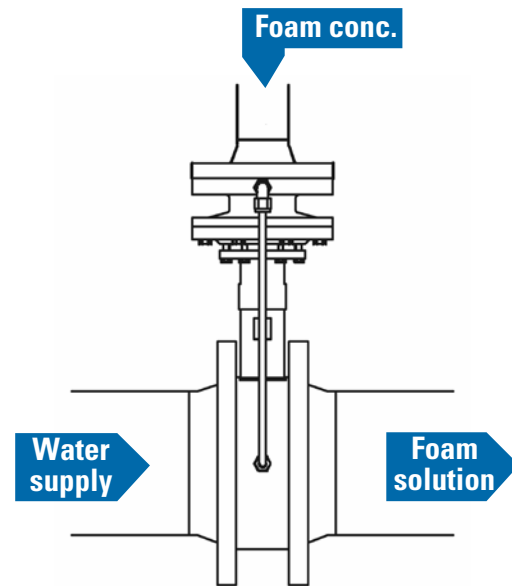
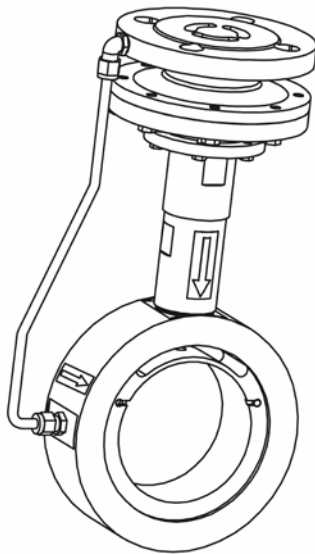

**Dimensions PP**

Type	A mm	B mm
■ PP-50	200	37
■ PP-80	220	37
■ PP-100	312	62
■ PP-150	333	62
■ PP-200	411	82
■ PP-250	439	82

## Performance Data PP MK2 Proportioners

Type	Connection		Capacity Min.		Capacity Max.		Weight		Max. Working Pressure		Material
	Foam*	Water	l/min	USGPM	l/min	USGPM	kg	lbs	bar	psi	
PP-50	3/4" BSP female	50 / 2"	125	33	800	211	6	13	16	235	Bronze (Cu88Sn12)
PP-80	3/4" BSP female	80 / 3"	300	79	2,000	528	10	22	16	235	Bronze (Cu88Sn12)
PP-100	50 / 2"	100 / 4"	770	203	6,100	1,612	18	40	16	235	Bronze (Cu88Sn12)
PP-150	50 / 2"	150 / 6"	1,500	396	18,000	4,756	21	46	16	235	Bronze (Cu88Sn12)
PP-200	80 / 3"	200 / 8"	2,875	760	26,500	7,000	43	95	16	235	Bronze (Cu88Sn12)
PP-250	80 / 3"	250 / 10"	5,100	1,347	37,850	10,000	53	117	16	235	Bronze (Cu88Sn12)

\* Flanges to fit DIN PN 16 or ANSI 150 lbs at least 1 bar  
1 bar = 0.1 MPa = 14.5 psi

<u>Part No.</u>	<u>Description</u>
■ 123005111	PP-50
■ 123008108	PP-80
■ 123310102A	PP-100 DIN/ANSI 3%
■ 123310102E	PP-100 DIN/ANSI 2%
■ 123310102B	PP-100 DIN/ANSI 1%
■ 123310102J	PP-100 DIN/ANSI 6%
■ 123315105A	PP-150 DIN/ANSI 3%
■ 123315105E	PP-150 DIN/ANSI 2%
■ 123315105B	PP-150 DIN/ANSI 1%
■ 123315105J	PP-150 DIN/ANSI 6%
■ 123320103A	PP-200 DIN 3%
■ 123320103E	PP-200 DIN 2%
■ 123320103B	PP-200 DIN 1%
■ 123320103J	PP-200 DIN 6%
■ 123320207A	PP-200 ANSI 3%
■ 123320207E	PP-200 ANSI 2%
■ 123320207B	PP-200 ANSI 1%
■ 123320207J	PP-200 ANSI 6%
■ 123325104A	PP-250 DIN 3%
■ 123325104E	PP-250 DIN 2%
■ 123325104B	PP-250 DIN 1%
■ 123325104J	PP-250 DIN 6%
■ 123325206A	PP-250 ANSI 3%
■ 123325206E	PP-250 ANSI 2%
■ 123325206B	PP-250 ANSI 1%
■ 123325206J	PP-250 ANSI 6%