



Balanced Pressure Proportioner - Wide range with Test Outlet

The IPPT is a Wide Range Proportioner that includes the ability to test the foam proportioning without mixing foam and water.

A complete installation can be tested for foam mixing percentage without discharging any foam. The foam concentrate is instead diverted and collected separately from the main flow and can, after the test, be returned to the foam tank. Because of this, regular testing of the system can be done with both environmental and economic benefits.

The IPPT provides a highly accurate proportioning ratio throughout its entire flow range combined with a low pressure drop. The IPPT is available with proportioning ratios from 1% up to 3% and is suitable for use with fresh or sea water and any type of foam concentrate.

The IPPT is especially well suited for the use of Fluorine Free (FF), ARC (alcohol resistant) and other types of high viscosity foam concentrates.

The IPPT is available from DN150 up to DN250 with flow ranges up to 23.000 lpm and can easily be incorporated into existing foam systems.

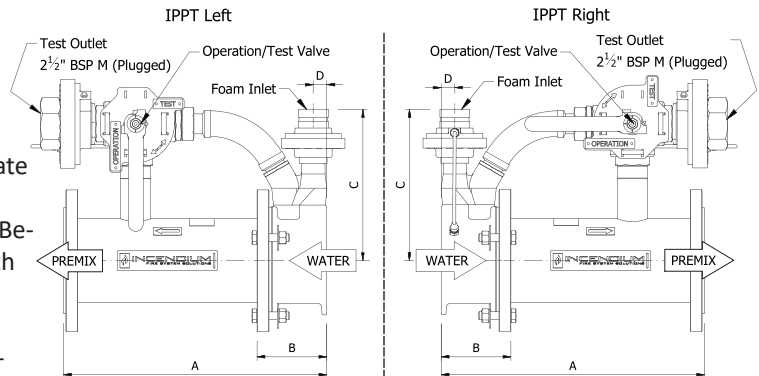

DIMENSIONAL DATA

Model	Length [mm]				Connection Water*	Connection Foam Inlet**	Weight [kg]
	A	B	C	D			
IPPT-150	530	141	304	28	DN150 / 6"	1½" BSP and DN50 G	55
IPPT-200	620	169	393	33	DN200 / 8"	2" BSP and DN65 G	85
IPPT-250	680	198	414	44	DN250 / 10"	2" BSP and DN65 G	125

* Mounted between flanges: DIN PN16 / ANSI 150lbs

** Foam Inlet is both Threaded BSP and Grooved ISO

All parts have been selected for reliable and trouble free service using corrosion resistant materials for low maintenance.

IPPT-250

Example installation with integrated IPPT system

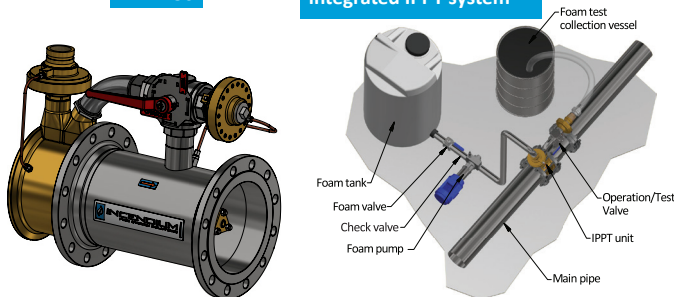

Material:

Body: Bronze and Stainless Steel (316L)
 Internals: Bronze and Stainless Steel (316L)
 Flanges*: Galvanized (Stainless Steel optional)

*IPPT-250 Stainless steel weld neck flanges as standard

Product Features

- Proportioning and testing function independent of foam concentrate type.
- Low pressure drop and accurate mixing over the entire flow range
- Customer specific, fixed proportioning ratio
- All models available as right or left flow direction
- Wide flow range up to 120:1
- Suitable for fluorine free foams, especially high viscosity/non-Newtonian properties
- Customer specific foam and test outlet connections available
- Economic and environmental friendly live foam testing without mixing water and foam concentrate
- Test Outlet hose available as option
- Designed and tested according to EN 13565-1
- Patent pending

PERFORMANCE DATA

Model	Flow Range [l/min]	Min. Straight Pipe Length Upstream	Min. Straight Pipe Length Downstream
IPPT-150	70-9000	300 mm	150 mm
IPPT-200	150-18000	400 mm	200 mm
IPPT-250	200-23000	500 mm	250 mm

PRESSURE DROP

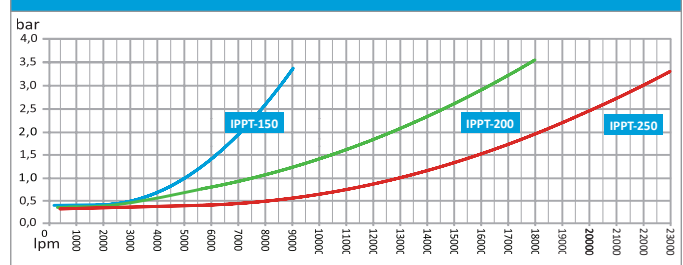

WORKING PRINCIPLE

