

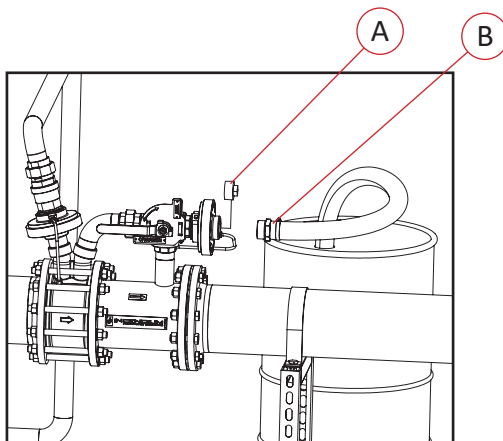

STEP 1

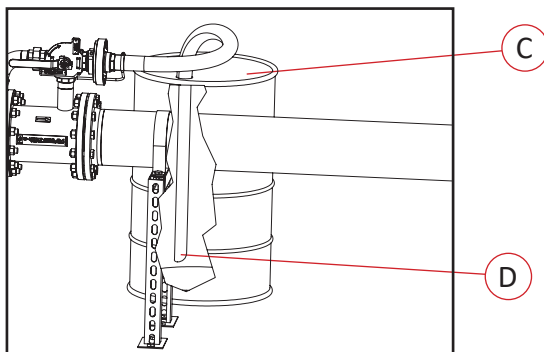

STEP 2



STEP 3

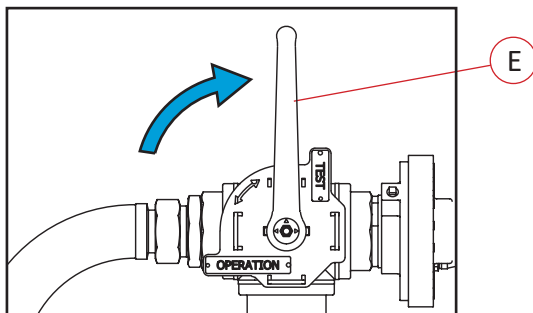

STEP 4

COMPLETE SYSTEM

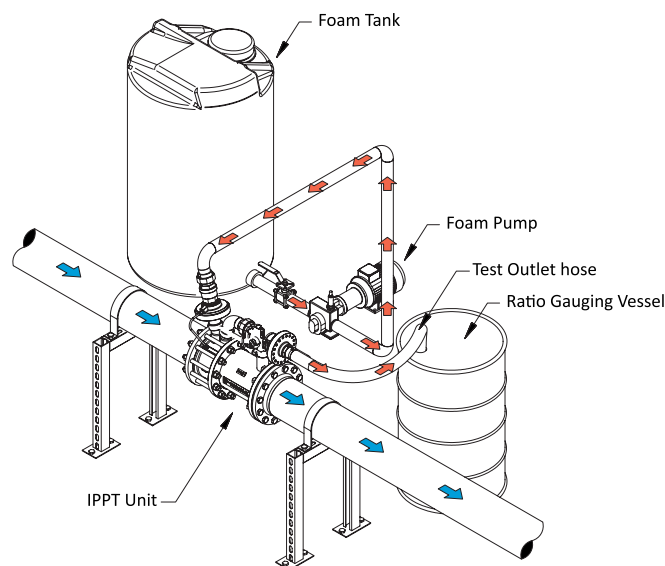

Instruction:

1. Remove drain plug in Test outlet (A) and replace it with a test hose (B).
2. Connect the test hose to a vessel (C) suited for measuring/gauging the volume of foam concentrate used during the test. Make sure that the test hose outlet (D) is as close to the bottom of the gauging vessel as possible to prevent aeration of the foam concentrate.
3. Maneuver the 3-way valve handle (E) to Test position.
4. The system setup works similarly to the sketch shown in step 4. The system is ready for test.
5. To execute an accurate test, the water volume should be measured by capacity/minute and run time of system. The amount of foam concentrate in the gauging vessel (C) can now be used to accurately calculate mixing percentage.
6. When the test has been completed, maneuver the handle of the 3-way valve (E) to Operation.
7. Remove the test hose (B) and replace it with the drain plug (A). The Foam concentrate can now be pumped back into the normal foam tank.
8. The system is now ready for normal operation.