

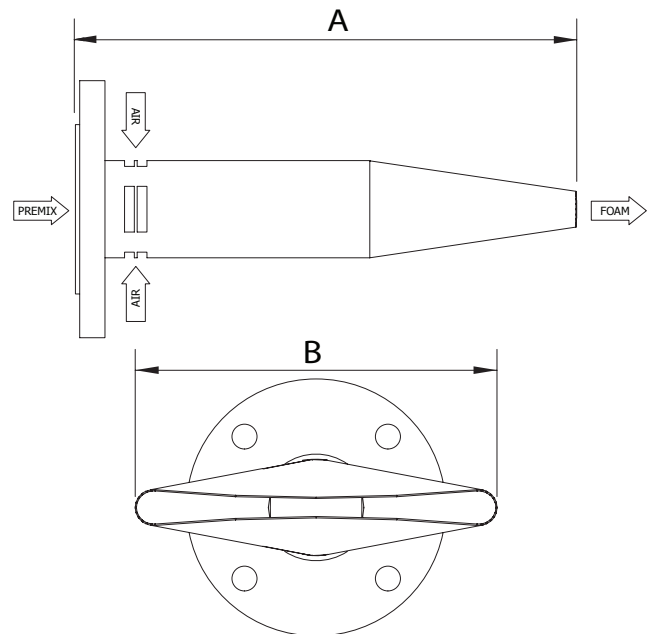

Low Expansion Foam Generator

The LFG, Low expansion Foam Generator is used for fixed installations. The design allows for rapid coverage of i.e. a bundled area and should be used together with a Class B foam concentrate. Due to the low expansion and the robust design the LFG is suitable for outdoor use also in harsh environment.

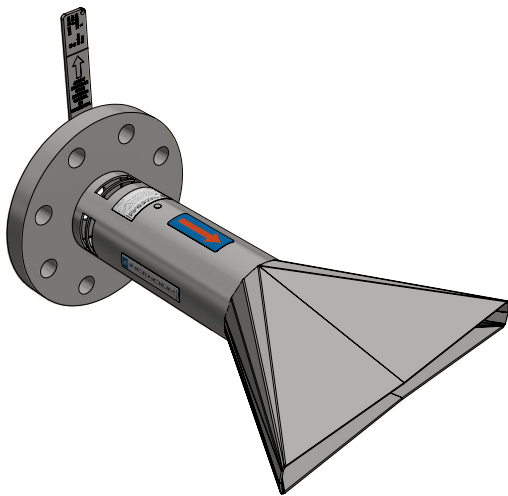

The generators can be dosed with most types of foam systems like foam pumps, bladder tanks or In-line proportioners.

The LFG produces a uniform low expanded foam with a nominal expansion ratio of approx 10:1, depending of the foam type.

Material:

Body: Stainless steel (316/316L)

Internals: Stainless steel (316/316L)

Flange*: Galvanized Steel

* Stainless steel optional

Product Features

- Stainless Steel construction
- Easily installed and low weight
- Maintenance free design
- Suitable for harsh environment
- Designed and tested according to EN 13565-1

DIMENSIONAL DATA

Model	Length [mm]		Inlet Connection (DIN PN16 / ANSI 150 lbs)	Weight [kg]
	A	B		
LFG-65	360	260	DN65 / 2.5"	5,5

All parts have been selected for reliable and trouble free service using corrosion resistant materials for low maintenance.

PERFORMANCE DATA

Model	Inlet Pressure [bar]	Water Capacity [lpm]	Foam Expansion Ration
LFG-65	4-16	90-1500	10:1