



## General description - OFG

Over the top foam generators are installed to the outside wall of liquid storage tanks above the level of stored product, producing and injecting foam onto the liquid surface.

Two types of generator are available, the OFG and OFGR, used for different types of tank construction, with a range of product performance and build options as described below.



## Application description - OFG

The OFG is connected to a foam concentrate supply to deliver foam onto the liquid surface within the tank. OFG units are suited to both fixed and floating roof storage tanks and are fitted with an in-situ test feature, accessed via an external test cover, enabling OFG test without discharging foam into the storage tank.

To select appropriate performance characteristics, refer to NFPA: National Fire Codes NFPA 11 and/or local regulations.

## Product features - OFG

- Stainless steel body construction with bronze orifice
- Hot-dipped galvanized slip-on inlet and outlet flanges
- Standard test outlet
- Factory calibrated to customer requirements
- Size and capacity fit to NFPA11 regulations
- Foam pourer with weld-on flange in carbon steel

## Connections

- Foam/water inlet: flanged according to DIN PN 16 or ANSI 150 lbs

## Approvals

- Factory Mutual approval for all OFG and OFGR models
- Chinese approval (TFRI)
- Russian State Fire Academy

## Options

- Complete unit in stainless steel
- Different connections standard

## Order information - OFG

Description	Part No.
OFG-50 T GS FIH-100 (complete) incl.	1413C05123
OFG-50 T GS DIN/ANSI	141305123
FIH-100 DIN	141210106
FIH-100 MOUNT. Details fzb	141210809
OFG-100 T GS FIH-150 (complete) incl.	1413C10126
OFG-100 T GS DIN/ANSI	141310126
FIH-150 DIN/ANSI	141215104
FIH-150 MOUNT. Details fzb	141215808

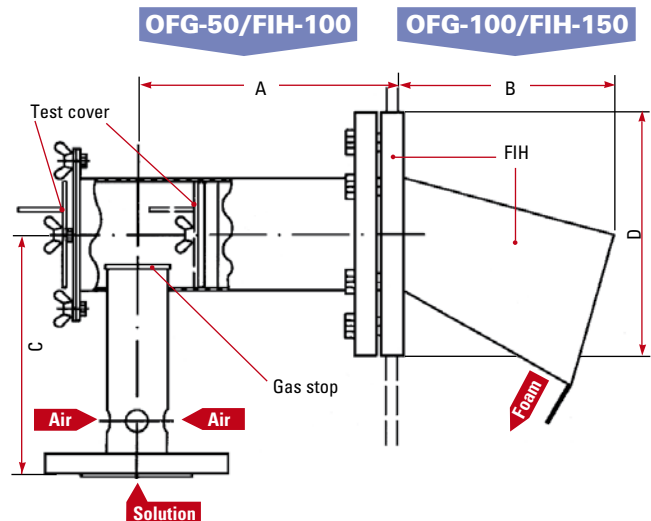

Performance Data			
OFG	50		100
Solution capacity	Up to 700 l/min	Up to 185 USGPM	700-3000 l/min 185-792 USGPM
Weight	20 kg / 44 lbs		32 kg / 71 lbs
Connection: OFG	50 DIN PN 16 and 2" ANSI 150 lbs		100 DIN PN 16 and 4" ANSI 150 lbs
FIH	To fit 100 DIN PN 16		FIH 150 DIN PN 16 and 6" ANSI 150 lbs
Dimension A	230 mm		300 mm
B	200 mm		250 mm
C	212 mm		320 mm
D	221 mm		286 mm
Expansion ratio	Up to 4:1*		
Material OFG Body	Stainless steel		
Internals	Bronze / Stainless steel		
Flange	Galvanized steel		
FIH Body	Stainless steel		
Flange	Steel		
Working pressure range	4-16 bar / 58-232 psi		
*Depending on foam concentrate type			



by Tyco Fire Suppression & Building Products

www.skum.com

Technical changes reserved without notice  
Copyright © 2009 Tyco Fire Suppression & Building Products

TYLENSKUM014 05/10



### Application description - OFGR

The Skum OFGRs are air-aspirated foam discharge devices that are designed to protect floating roof, flammable liquid storage tanks. They can be used on open top constructions with either a double deck or pontoon type floating roof.

### Product features - OFGR

- Stainless steel body
- Hot-dipped galvanized weld-on slip-on flange
- Optional test outlet (OFGR-T only)
- Factory calibrated to any flow and pressure within the range
- Sizes and capacity fit to NFPA 11 regulations

### Order information - OFGR - please specify:

1. Part number
2. Capacity: flow and pressure



Description	Part No.
OFGR-50 DIN/ANSI	141005354
OFGR-50 T DIN/ANSI	141005305
OFGR-100 DIN/ANSI	141010412
OFGR-100 T DIN/ANSI	141010405

T = Foam Test Outlet

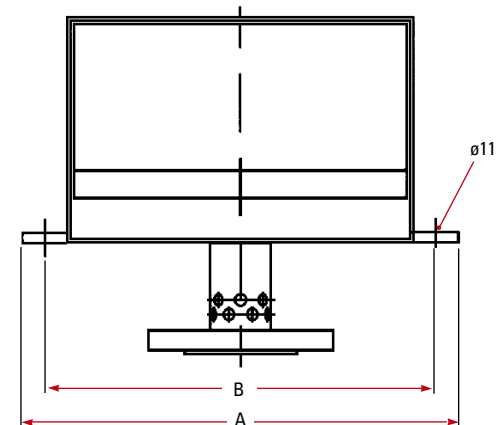
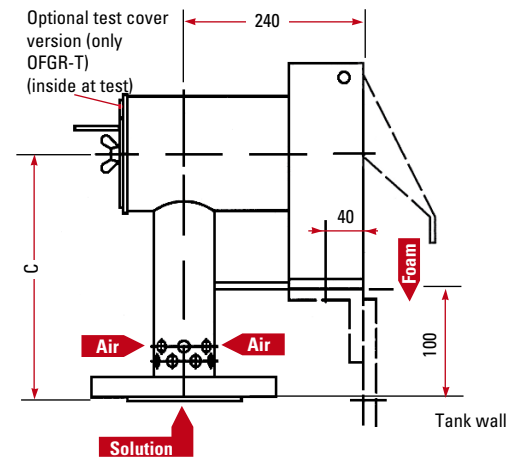

Performance Data				
OFGR	50	50T	100	100T
Solution capacity	Up to 700 l/min Up to 185 USGPM		700-3000 l/min 185-792 USGPM	
Weight	13 kg / 29 lbs	14 kg / 31 lbs	21 kg / 46 lbs	22 kg / 49 lbs
Connection	50 DIN PN 16 and 2" ANSI 150 lbs		100 DIN PN 16 and 4" ANSI 150 lbs	
Dimension	A	430 mm	580 mm	
	B	390 mm	540 mm	
	C	255 mm	320 mm	
Working pressure	4-16 bar / 58-232 psi			
Expansion ratio	Up to 4:1*			
Material	Body	Stainless steel		
	Flange	Galvanized steel		

\*Depending on foam concentrate type 1 bar = 0,1 MPa = 14,5 psi



by Tyco Fire Suppression & Building Products

www.skum.com

Technical changes reserved without notice  
Copyright © 2009 Tyco Fire Suppression & Building Products

TYLENSKUM014 05/10