

Fog/Jet Monitor Manual FJM-MAN

General Description

A range of manually operated fog/jet water/foam monitors with exceptional flow characteristics that optimise throw range. This gives exceptional delivery of water or foam as a jet or as a spray pattern. The range is available for a number of alternate mounting positions. The two main types are the FJM and the FJM-S; the FJM-S has an in-built foam concentrate inductor, eliminating the need for a separate proportioning system.

Application Description

The FJM range of fog/jet monitors are designed for easy operation, reliability and are more lightweight due to lighter construction materials.

FJM monitors have a wide operating range and are site adjustable to any demands of the local environment, whilst still maintaining the highest level of performance.

Note that when running any of the FJM-S range of monitors, the monitor needs to be adjusted to nominal capacity for accurate proportioning.

Product Features

- Wide capacity range
- Adjustable flow
- Compact, balanced design
- Low weight
- Easily manoeuvred due to low friction bearings
- Long throw length
- Adjustable stream pattern
- Corrosion resistant construction of stainless steel and bronze

Connections

- Foam/water inlet: flanged according to DIN PN 16, JIS 10K or ANSI 150 lbs

Optional Components

- Built-in inductor optional on all models ('S' Version)
- Gear operation; optional for FJM-150, standard for FJM-200
- Optional suction hose and valve



Listings and Approvals

- Det Norske Veritas DNV
- Bureau Veritas
- Factory Mutual (FM)
- Tanusitvany (Hungary)
- OKF (Hungary)
- KFSD (Kuwait)
- Russian Maritime Register of Shipping (RMRS)



Order Information - Please Specify

1. Part number
2. Type
3. Flange type
4. Capacity: flow and pressure
5. Motor and Solenoid voltage
6. Foam induction (S-version)

Ordering Information

Part No.	Description
■ 161008407	FJM-80 DIN/ANSI
■ 161008319	FJM-80 DIN/JIS
■ 161008340	FJM-80 S DIN/ANSI, excl. suction hose
■ 161008551	FJM-80 S DIN/JIS, excl. suction hose
■ 161008618	FJM-80 suction hose 1 1/4" 3m
■ 161010403	FJM-100 DIN/ANSI
■ 161010209	FJM-100 DIN/JIS
■ 161010315	FJM-100 S DIN/ANSI, excl. suction hose
■ 16101606	FJM-100 suction hose 2" 3m
■ 161015304	FJM-150 DIN/ANSI/JIS
■ 161015405	FJM-150 S DIN/ANSI, excl. suction hose
■ 161315317	FJM-150 G DIN/ANSI/JIS
■ 161315338	FJM-150 S G DIN/ANSI/JIS, excl. suction hose
■ 161015608	FJM-150 suction hose 2" 3m
■ 161320127	FJM-200 G DIN
■ 161320229	FJM-200 G ANSI
■ 162020260	FJM-200 S G ANSI, excl. suction hose

FJM-80

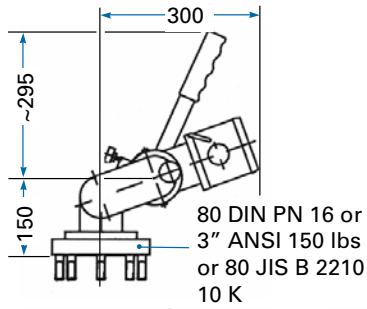

FJM-80 S

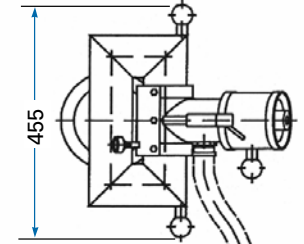
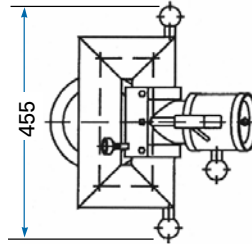
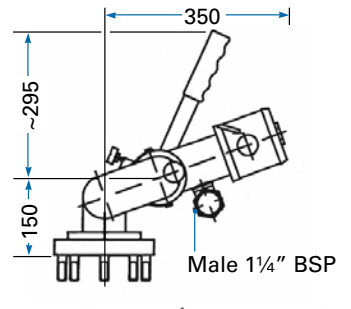

FJM Monitors - Capacity Ranges

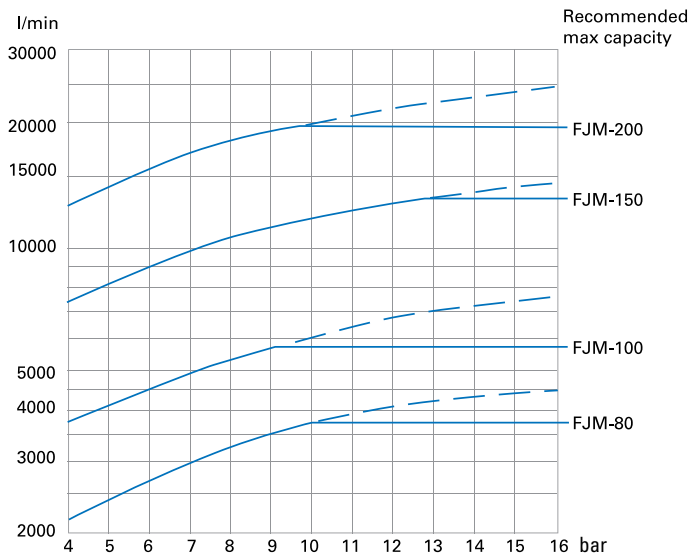

FJM-80 Monitor - Range of Jet

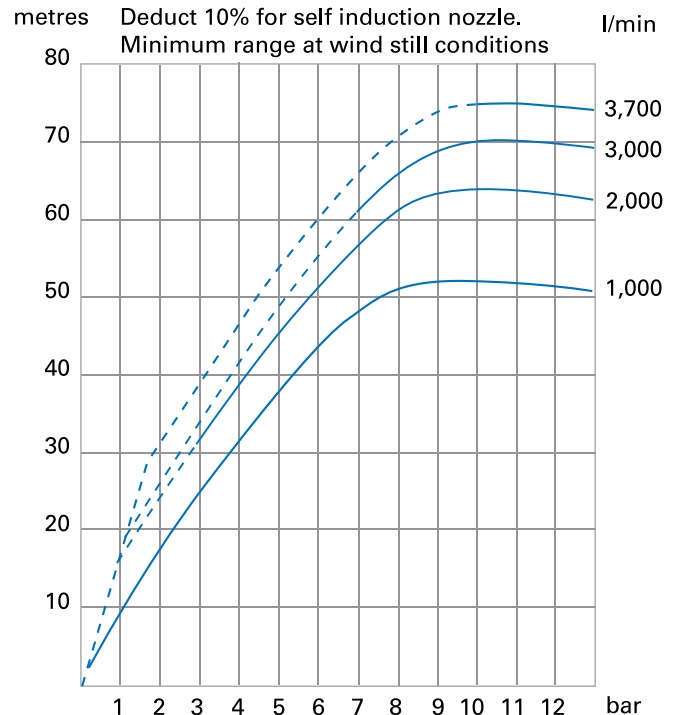

Reaction force (N) = 0.233 x Q (l/min) x √p (bar)

FJM-100

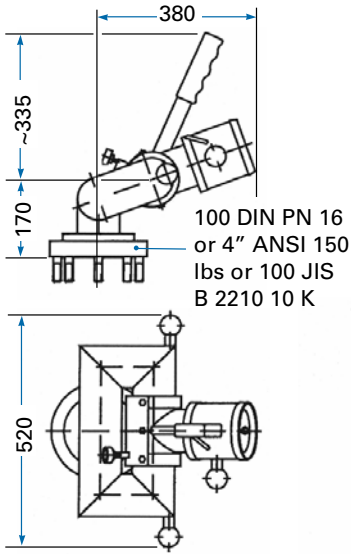

100 DIN PN 16
or 4" ANSI 150
lbs or 100 JIS
B 2210 10 K

FJM-100 S

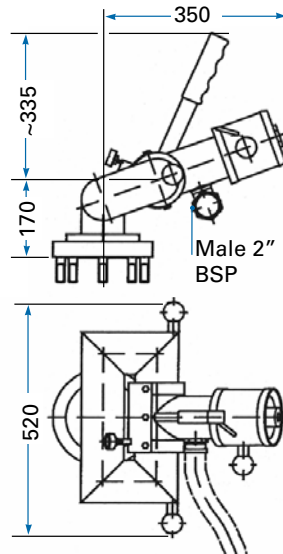

Male 2"
BSP

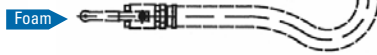

FJM-150

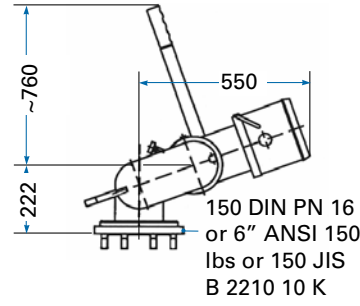

150 DIN PN 16
or 6" ANSI 150
lbs or 150 JIS
B 2210 10 K

FJM-150 S

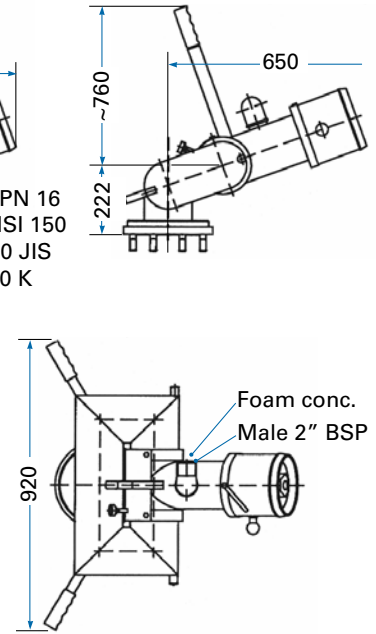

Foam conc.
Male 2" BSP

FJM-100 Monitor - Range of Jet

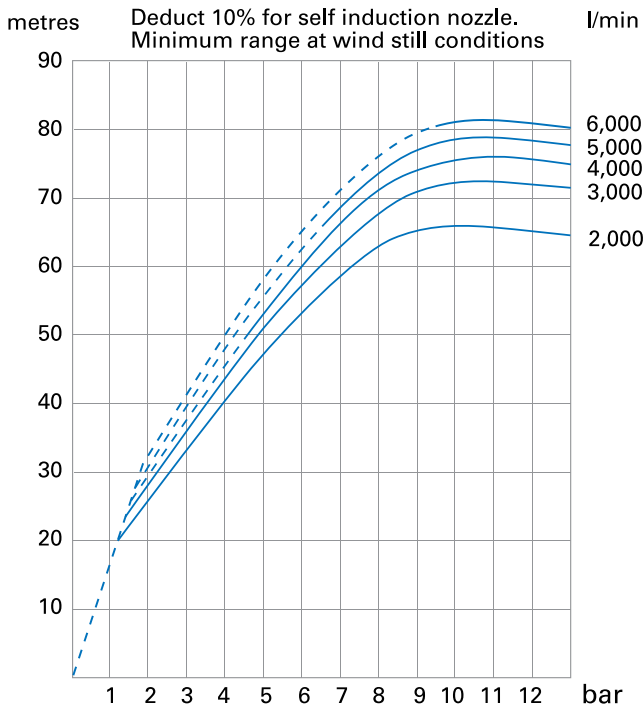

Reaction force (N) = 0.233 x Q (l/min) x √p (bar)

FJM-150 Monitor - Range of Jet

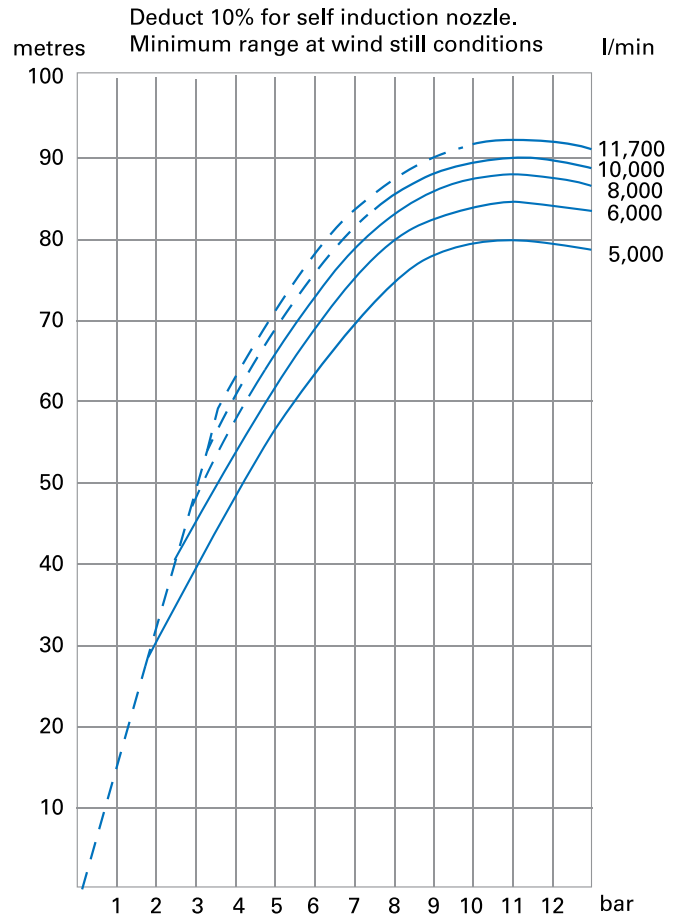

Reaction force (N) = 0.233 x Q (l/min) x √p (bar)

FJM-150 G

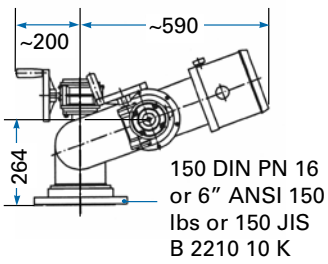

FJM-150 SG

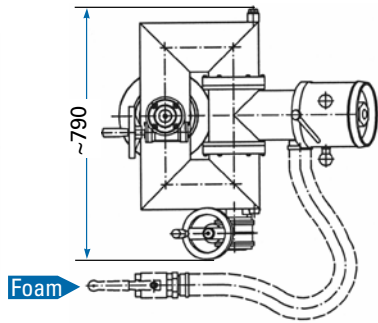
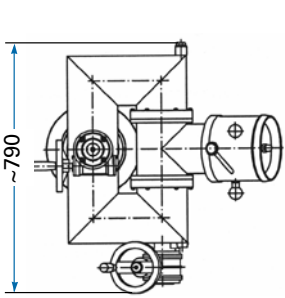
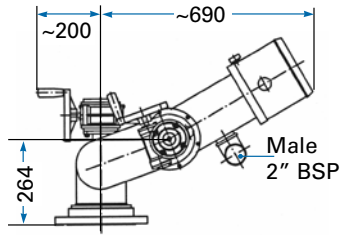

FJM-200 G

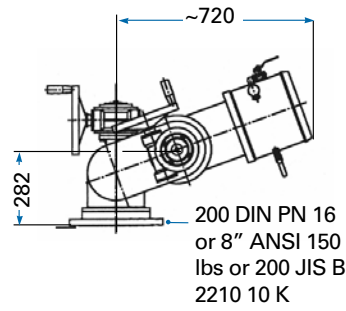

FJM-200 SG

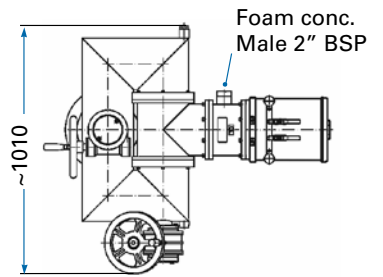
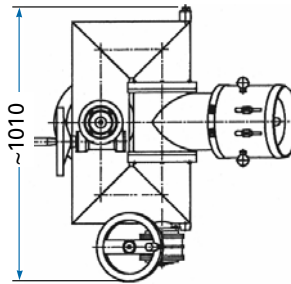
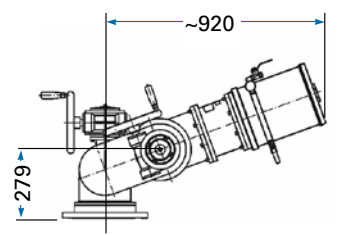

FJM-150 Monitor - Range of Jet

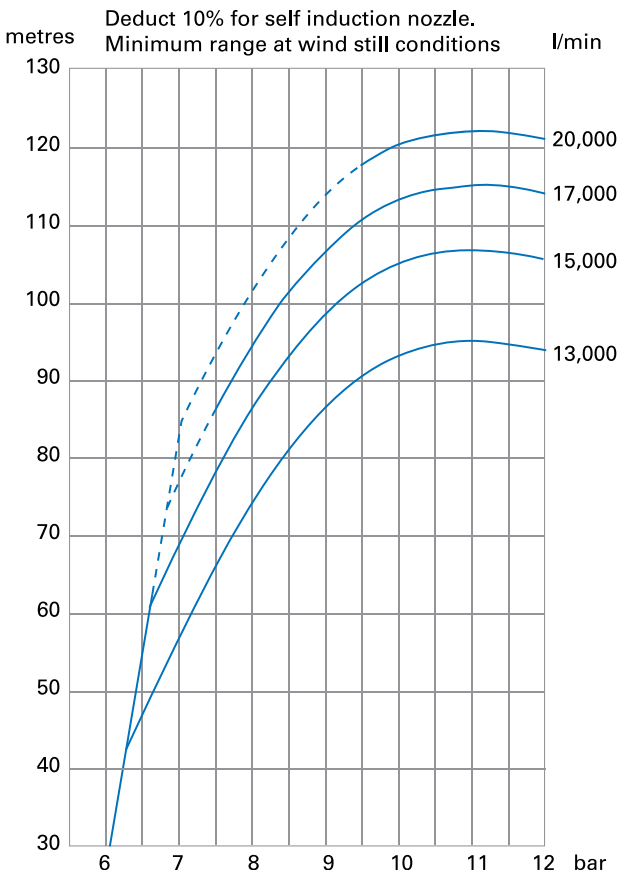

FJM Monitors - Average Fog Pattern (in still air)

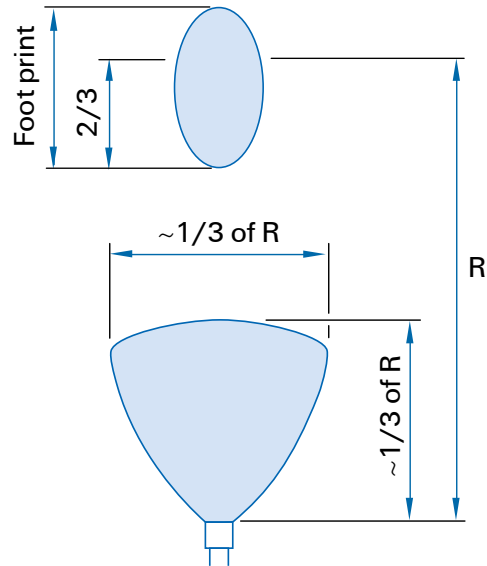

Performance Data

FJM Series Standard	80	100	150	200
■ Water capacity	max 3,700 l/min min 500 l/min	max 6,000 l/min min 1,000 l/min	max 11,700 l/min min 3,000 l/min	max 20,000 l/min min 8,000 l/min
■ Design pressure	4-16 bar optimum 10-12 bar	4-16 bar optimum 10-12 bar	4-16 bar optimum 10-12 bar	4-13 bar optimum 10-12 bar
■ Rotation	360°	360°	360°	360°
■ Elevation	-60° / +90°	-60° / +90°	-60° / +70°	-60° / +70°
■ Connection flange	Stud bolt	Stud bolt	Open hole	Open hole
■ Weight	14 kg / 31 lbs	22 kg / 49 lbs	57 kg / 126 lbs	90 kg / 199 lbs
FJM Series Built-in inductor	80	100	150	200
■ Water capacity	max 3,700 l/min min 500 l/min	max 6,000 l/min min 1,000 l/min	max 11,700 l/min min 3,000 l/min	max 20,000 l/min min 8,000 l/min
■ Design pressure	4-16 bar optimum 10-12 bar	4-16 bar optimum 10-12 bar	4-16 bar optimum 10-12 bar	4-13 bar optimum 10-12 bar
■ Foam capacity	170 l/min	320 l/min	600 l/min	600 l/min
■ Elevation	-45° / +90°	-45° / +90°	-45° / +70°	-45° / +70°
■ Suction connection	1¼" BSP male	2" BSP male	2" BSP male	2" BSP male
■ Weight	15 kg / 33 lbs	24 kg / 53 lbs	60 kg / 132 lbs	93 kg / 205 lbs