

Fog/Jet Monitor Oscillating FJM-WTO

General Description

A range of manually operated fog/jet, water and foam monitors with exceptional flow characteristics that optimise throw range. This gives exceptional delivery of water or foam as a jet or as a spray pattern. The FJM 80 WTO, 100 WTO and 150 WTO units are self-oscillating with internal water-driven turbines. Unique design and stainless steel construction add to the relatively low weight of this unit.

Application Description

FJM WTO units are designed for fixed mounting, enabling effective application of the wide flow range optimised jet range and spray patterns. The loose flange allows for easy mounting and adjustment for oscillating area sweep.

'S' Models

The 'S' model comes complete with built in foam induction.

Product Features

- Wide flow range
- Adjustable flow
- Compact, balanced design
- Low weight
- Easily manoeuvred due to low friction bearings
- Long throw length
- Adjustable stream pattern
- Corrosion resistant construction of stainless steel and bronze construction
- Manual override
- Slip on inlet connection flange for direction adjustment

Connections

- Foam/water inlet: flanged according to DIN PN 16, or ANSI 150 lbs

Optional Components

- Built-in inductor optional on all models ('S' Version)
- Optional suction hose and valve



Listings and Approvals

- Det Norske Veritas DNV
- Bureau Veritas (BV)
- Factory Mutual (FM); FJM-80 WTO
- Tanusitvany (Hungary)
- KFSD (Kuwait); FJM-80 WTO
- Russian Maritime Register of Shipping (RMRS)



Order Information - Please Specify

1. Part number
2. Type
3. Flange type
4. Capacity: flow and pressure (optional)
6. Foam induction (S-version)

FJM-80 WTO

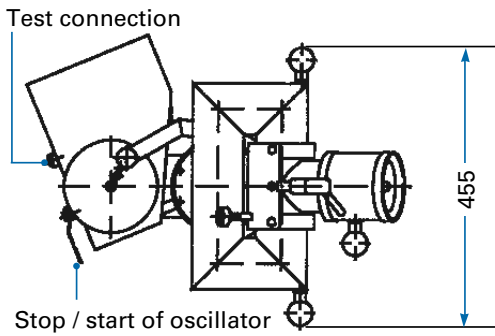
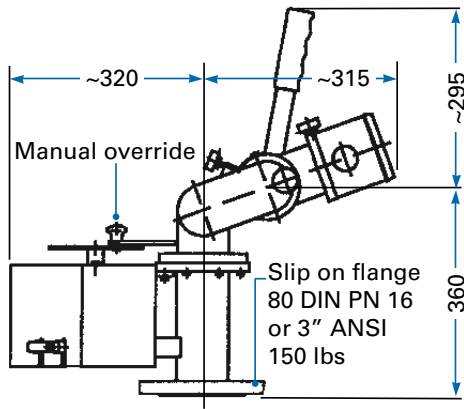

FJM-80 WTO S

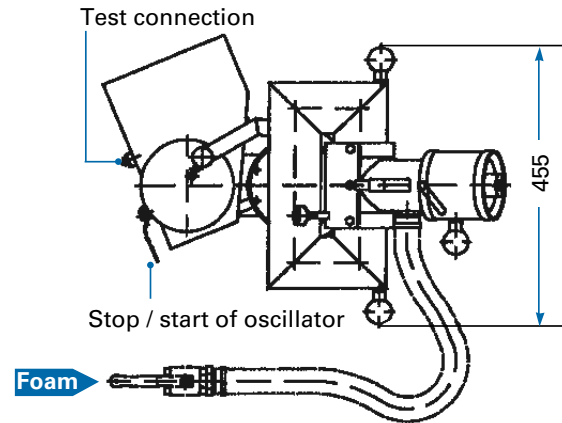
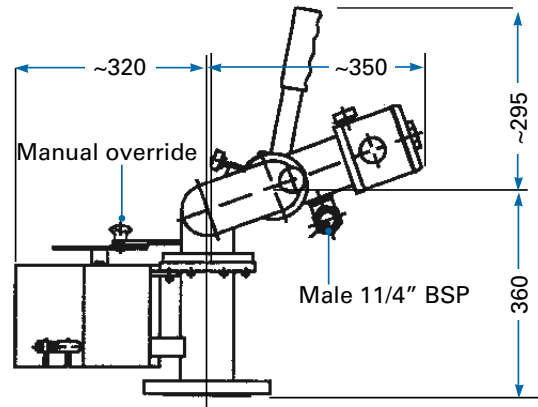

FJM-80 Monitor - Range of Jet

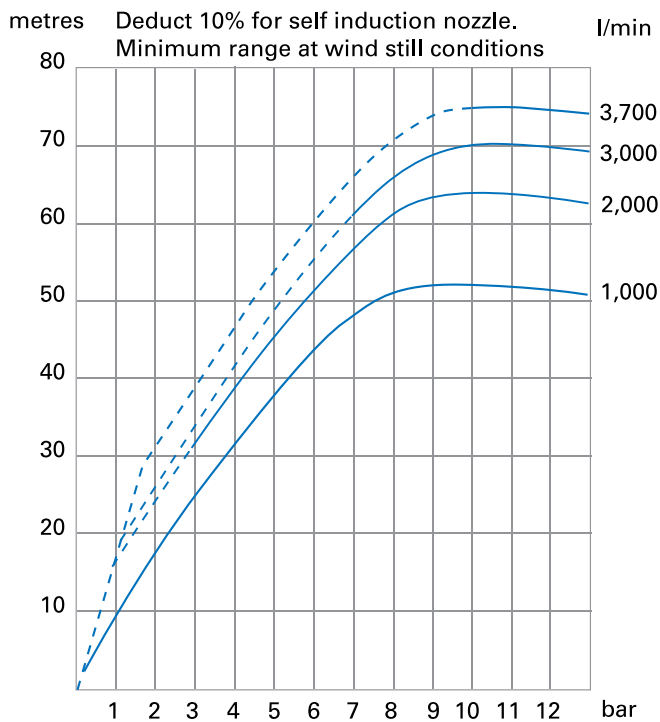

FJM-100 WTO

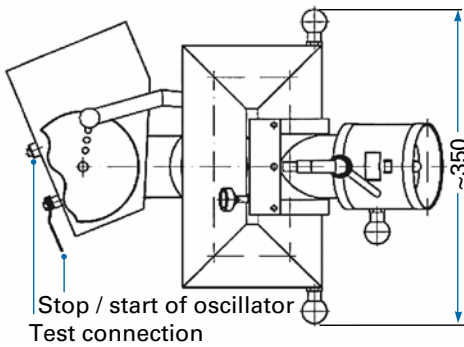
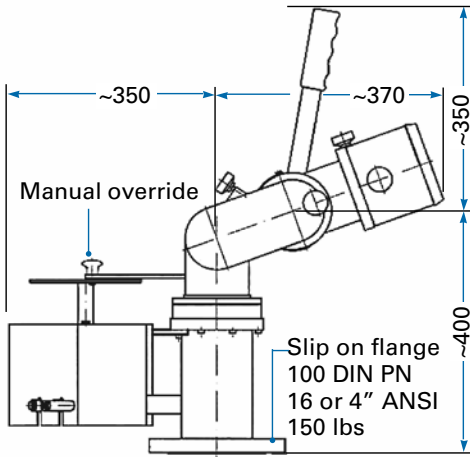

FJM-100 WTO S

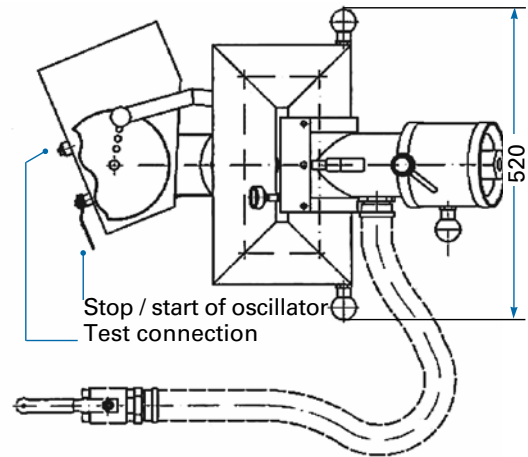
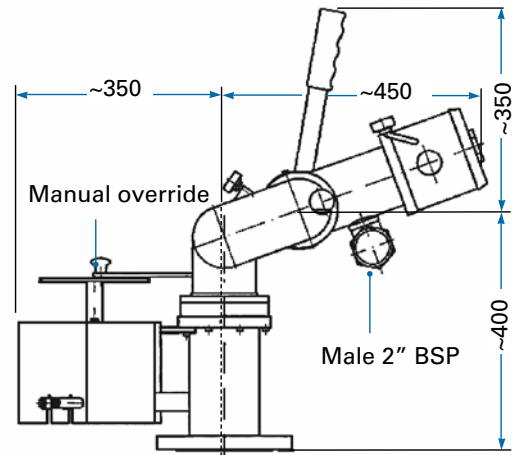

FJM-100 Monitor - Range of Jet

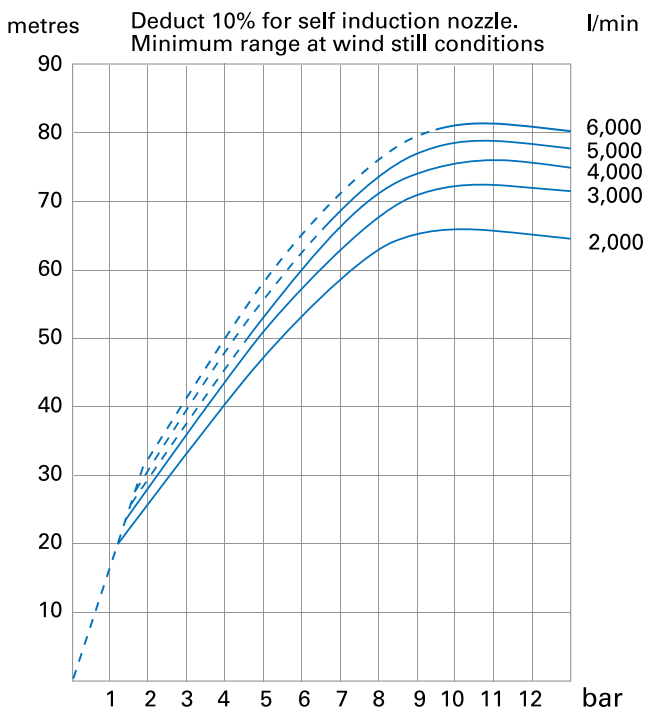

FJM-150 WTO

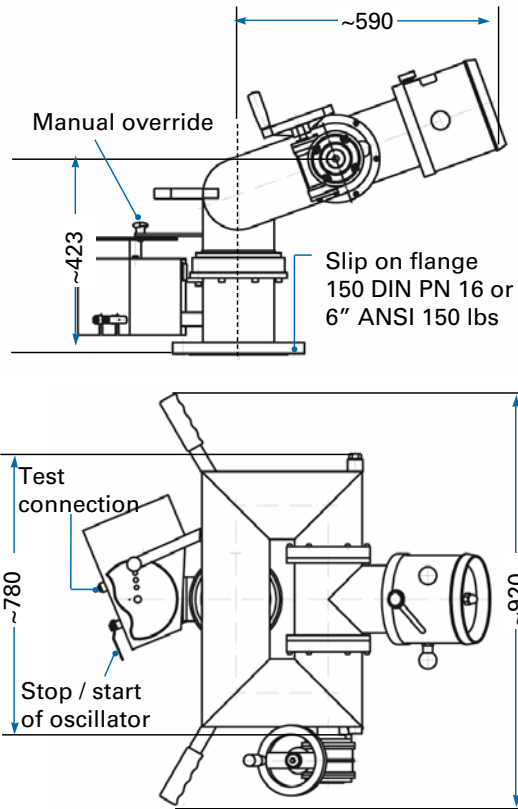

FJM Monitors - Average Fog Pattern (in still air)

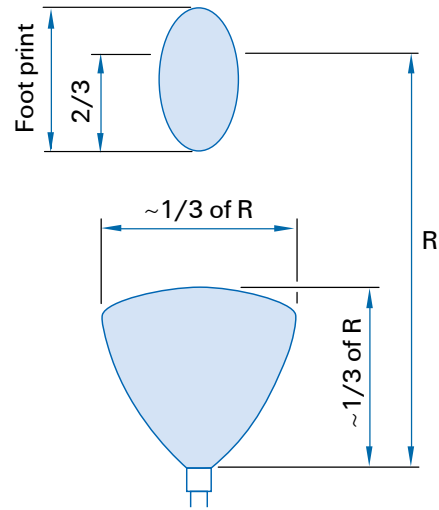

FJM-150 Monitor - Range of Jet

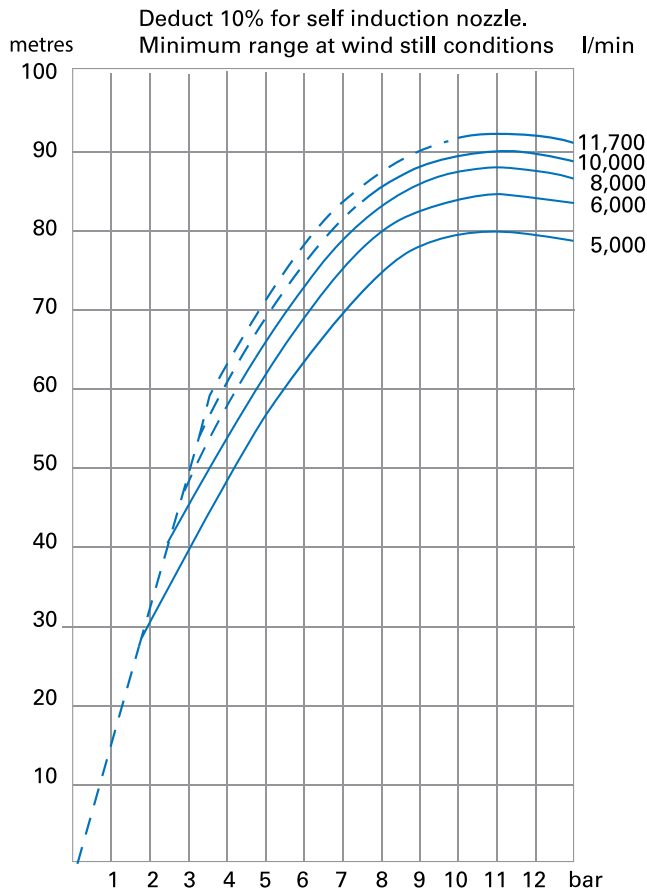

FJM Monitors - Capacity Ranges

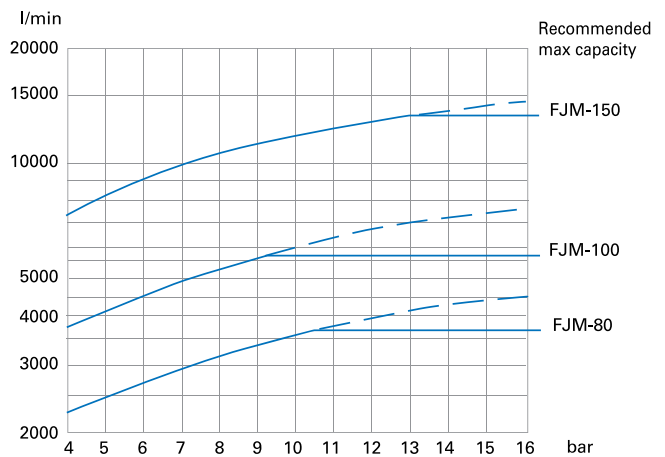

Performance Data

FJM - WTO Standard	80	100	150
■ Water capacity	max 3,700 l/min min 500 l/min	max 6,000 l/min min 1000 l/min	max 11,700 l/min min 3000 l/min
■ Design pressure	4-16 bar optimum 10-12 bar	4-16 bar optimum 10-12 bar	4-16 bar optimum 10-12 bar
■ Rotation - oscillation			
■ Rotation - manual	360°	360°	360°
■ Elevation - manual	-60° / +90°	-60° / +90°	-60° / +90°
■ Weight	25 kg	32 kg	67 kg
■ Connection: water	80 DIN PN 16 or 3" ANSI 150 lbs	100 DIN PN 16 or 4" ANSI 150 lbs	150 DIN PN 16 or 6" ANSI 150 lbs
■ Material: body	Stainless steel	Stainless steel	Stainless steel
■ Material: Flange	Galvanised steel	Galvanised steel	Galvanised steel
■ Material: nozzle	Bronze	Bronze	Bronze

Reaction force (N) = 0.233 x Q (l/min) x √p (bar)

Ordering Information

<u>Part No.</u>	<u>Description</u>
■ 161508716	FJM-80 WTO DIN
■ 161508819	FJM-80 DIN ANSI
■ 161508737	FJM-80 S WTO DIN, excl. suction hose
■ 161508840	FJM-80 S WTO ANSI, excl. suction hose
■ 161008618	FJM-80 suction hose 1 ¼" 3m
■ 161510811	FJM-100 WTO DIN/ANSI
■ 161510761	FJM-100 S WTO DIN/ANSI, excl. suction hose
■ 161010606	FJM-100 suction hose 2" 3m
■ 161515719	FJM-150 WTO DIN/ANSI/JIS
■ 161015608	FJM-150 suction hose 2" 3m