

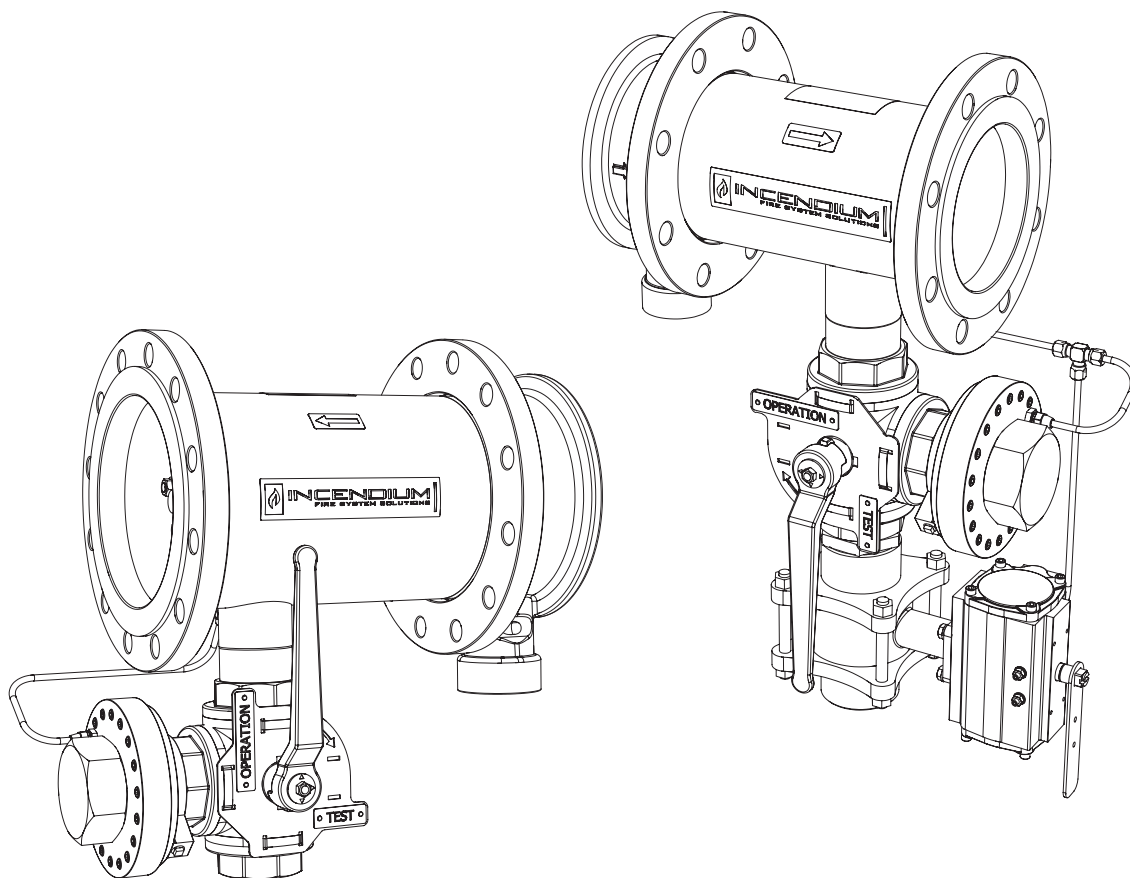

VIP

OPERATION AND MAINTENANCE



Technical changes reserved without notice



INDEX

<u>CONTENTS</u>	<u>PAGE</u>
<u>1. GENERAL DESCRIPTION</u>	<u>3</u>
1.1 Liability Warning	3
1.2 Installation	3
<i>1.2.1 Safety</i>	<i>3</i>
1.3 Warranty	3
<u>2. HAZARD WARNING</u>	<u>4</u>
<u>3. FUNCTION AND HANDLING</u>	<u>4</u>
<u>4. TEST PROCEDURE</u>	<u>5</u>
4.1 Safety	5
4.2 Preparation before test	5
4.3 Run test	5
4.4 Reset after test	6
4.5 Test conclusion	6
<u>5. UPKEEP</u>	<u>7</u>
5.1 Maintenance	7
<i>5.1.2 Every 2 months</i>	<i>7</i>
<i>5.1.2 Every year</i>	<i>7</i>
5.2 Service	7
<u>6. GENERAL TROUBLESHOOTING</u>	<u>7</u>
<u>7. OTHER DOCUMENTATION</u>	<u>7</u>



1. GENERAL DESCRIPTION

The Viscosity Independent Proportioner, VIP, is a Wide Range Tank Proportioner that includes the ability to test the foam proportioning without mixing foam and water. A complete installation can be tested for foam mixing percentage without discharging any foam. The foam concentrate is instead diverted and collected separately from the main flow and can, after the test, be returned to the foam tank. Because of this, regular testing of the system can be done with both environmental and economical benefits.

Please read through this entire manual before using the VIP.

Incendium is not responsible for any accidents that occur if not following the instructions in this document.

1.1 Liability Warning

The VIP must be operated and maintained in compliance with this document as well as with applicable standards, in addition to the standards of any other authorities having jurisdiction. Failure to do so may impair the proper operation or integrity of this device.

The owner is responsible for maintaining his fire protection unit or system and devices in proper operating conditions. The manufacturer or reseller should be contacted relative to any questions.

This manual must be read and understood by all personnel involved in operation, calibration and maintenance of this product and shall be kept in an accessible place for review. Take note that the appearance of the product in this manual may differ from the delivered product. The functions are however the same and thus, this manual must be followed to every step.

The unit should not under any circumstances be operated outside the parameters indicated in this manual. Operation of this device without understanding this manual can be dangerous.

1.2 Installation

For standard installation instructions, please see documents (order specific instructions can also be provided):
Installation instruction, document designation: II-0011-VIP-EN

1.2.1 Safety

The following points must be respected during installation:

- The installation must be carried out by qualified personnel. The directions given in the installation instruction must be followed.
- Make sure that the VIP is safely secured when installing and running the system.
- Use only lifting gear and equipment that are well suited for the purpose.
- Do not lift the unit by hand.
- Before start up of testing make sure there is no personal in the affected area.

1.3 Warranty

Seller warrants for a period of one year from date of shipment (warranty period) that products furnished hereunder will be free from defects in material and workmanship.

This warranty is invalid if the device is or has been:

- Misused or neglected
- If there have been accidents to the equipment
- Altered in any way
- Instructions in this manual has not been followed



2. HAZARD WARNING

Operating the VIP is safe as long as the correct mode (operation / test) is used and the design pressure is not exceeded. The plug at the Test Outlet should not be removed except for when testing is performed. After testing has been completed the plug should be set in place again to prevent any foam concentrate from exiting the proportioner at undesirable times. Please see "4. Test Procedure" on page 5 for further details before performing a test.

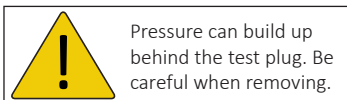
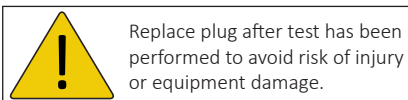
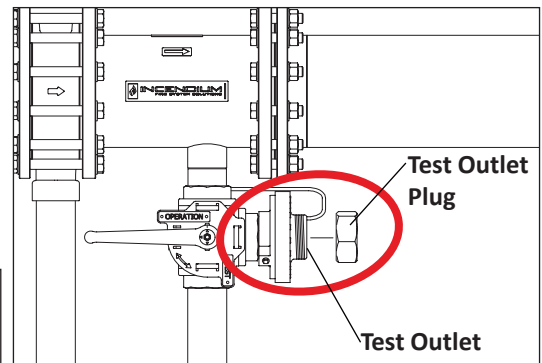

3. FUNCTION AND HANDLING

The VIP can be installed in foam mixing systems that uses a bladder tank. The VIP uses a self adjusting water flow disc and is used as an inverted proportioner. Instead of mixing in foam, the proportioner diverts a fixed percentage of the water flow and into a bladder tank. The foam concentrate in the bladder tank is then directed into the water main of the system. Effectively, the fixed water amount diverted out through the VIP is thusly replaced by foam concentrate. The bladder tanks foam connection is then connected to the Test Outlet (standard) part of the VIP. This consists of a three-way valve and a pressure balancing valve which simulates the main water line counter pressure. From here the foam concentrate can be directed to the main water pipe or to a gauging vessel. After a foam test has been completed the foam used for measuring mixing ratio can be pumped back into the foam tank.

Using the VIP during normal operation is simple. Water main flow automatically activates the optional Automatic Foam Valve if present (Some systems use previously installed automatic valves for this). The Bladder tank is also pressurized. Foam flows from the bladder tank to the 3-way valve. This valve is set to either test or operation mode by maneuvering the 3-way valve handle. The handle should always be set in operation mode unless an active test is performed. See "4. Test Procedure" on page 5 for further instruction

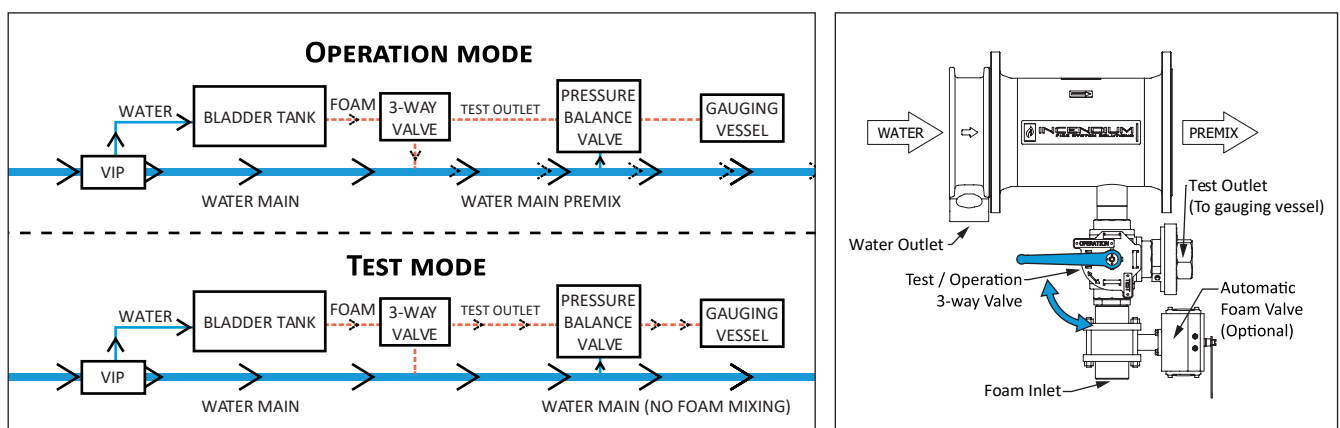



4. TEST PROCEDURE

Performing a mixing ratio test of a foam system is important and ensures that the system is in full working order. Follow the steps below to perform the mixing ratio test of the VIP.

4.1 Safety

- Before start up of the test make sure there is no unauthorized personnel in the area affected of the test.
- Inspect the bladder tank and VIP as well as the auxiliary equipment for damage before the test. Abort the test if there is any damage to equipment that can interfere with the test.
- The person performing the test should always wear appropriate safety equipment according to MSDS for the foam concentrate in question.
- Follow every step in 4.2 - 4.5 for a complete test of the VIP system
- Contact Incendium if any problems arise

4.2 Preparation before test

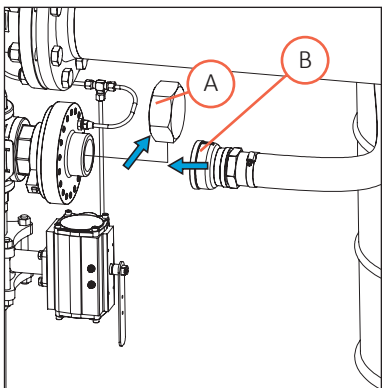
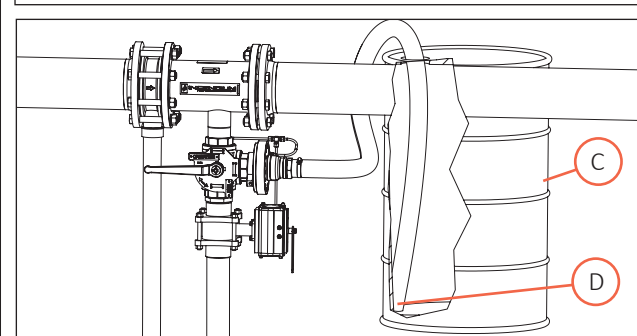
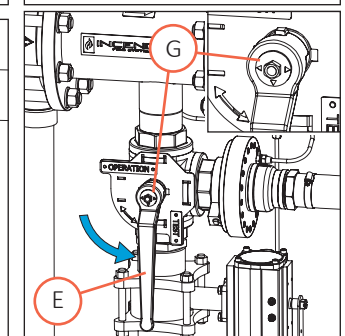
<p>1. Remove drain plug in Test outlet (A) and replace it with a test hose (B).</p>	<p>2. Connect the test hose to a vessel (C) suited for measuring/gauging the volume of foam concentrate used during the test. Make sure that the test hose outlet (D) is as close to the bottom of the gauging vessel as possible to prevent aeration of the foam concentrate.</p>	<p>3. Maneuver the 3-way valve handle (E) to Test position. Indication disc (G) shows the position of openings in the ball valve.</p>
		

4.3 Run test

4. The system setup works similarly to the sketch shown here. The system is ready for test. To execute an accurate test, the water volume should be measured by capacity/minute and run time of system. The amount of foam concentrate in the gauging vessel (C) can be used to accurately calculate mixing percentage.

For example, a 1000 lpm system that runs for 5 minutes and has a foam mixing percentage of 3% gives the following calculation:

$$1000 * 5 * 0,03 = 150L$$

The measures volume in the gauging vessel should be at least 150L or just above to receive the correct mixing percentage.

Continue on the next page

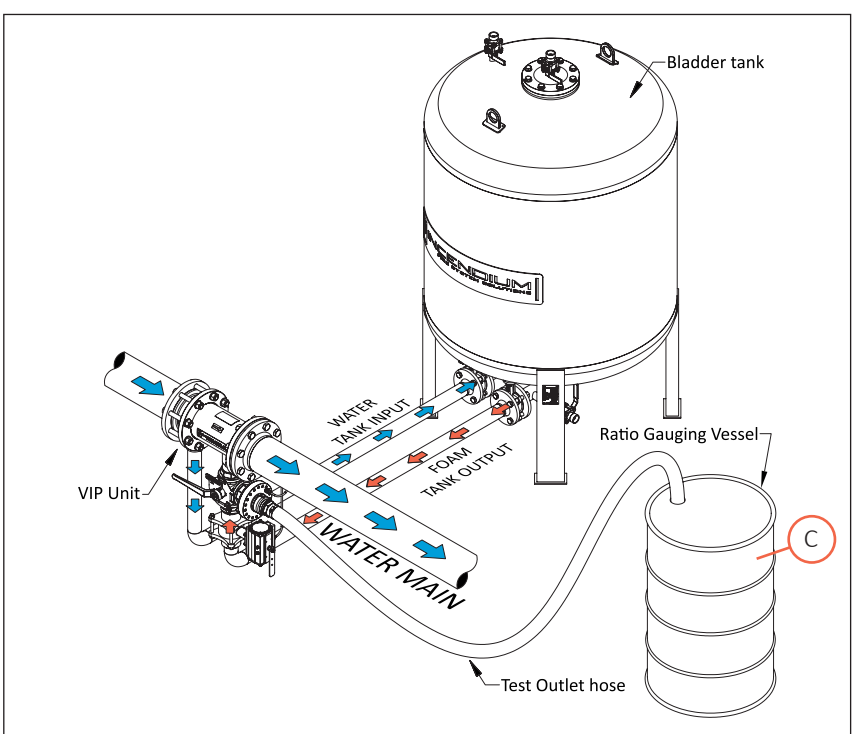



4.4 Reset after test

5. When the test has been completed, maneuver the handle of the 3-way valve (E) to Operation.

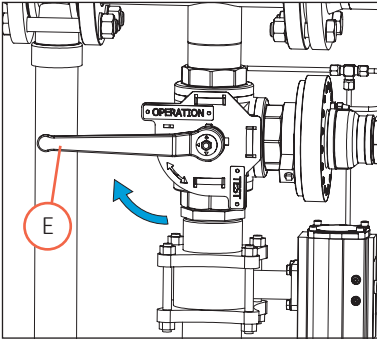

6. Remove the test hose (B) and replace it with the drain plug (A).

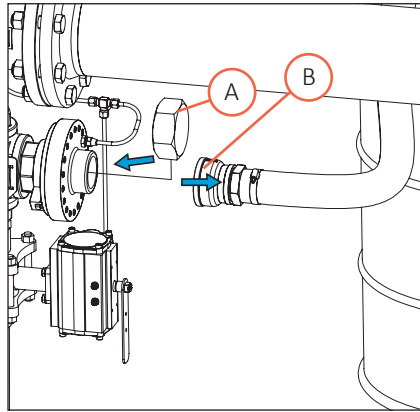

7. Check that for any unwanted properties or contamination of the foam concentrate like, for example, bubbles which can take form if the test hose outlet is not properly situated during the test. If no issues are discovered the foam concentrate used for the test can now be pumped back into the bladder tank.

The system is now ready for normal operation.

4.5 Test conclusion

The test is now concluded. Report any deviations from expected results as in behavior of the system or regarding mixing percentage. This report should be forwarded to management or Incendium if any problems persist



5. UPKEEP

5.1 Maintenance

The VIP does not normally need any maintenance but should be inspected at certain intervals to ensure that it functions correctly. It is also recommended that a mixing ratio test is done at least once a year to ensure that the proportioner and auxiliary equipment are in working order.

5.1.2 Every 2 months

- Check that all bolts are tightened correctly
- Inspect the VIP unit as well valves and other connections to ensure that no leaks are present.

5.1.2 Every year

- Perform a mixing ratio test according to “4. Test Procedure” on page 5

5.2 Service

Service needed for the VIP is minimal. In case of equipment malfunction the troubleshooting guide should be followed in chapter 5. If any repairs are required, use only personnel trained specifically for the task with good knowledge of the VIP and its function. Contact Incendium for counseling.

6. GENERAL TROUBLESHOOTING

The VIP does not induce any foam at all:

- Check the VIP is installed in the correct flow direction
- Check that all valves are in the correct position
- Check that the proportioner is working in the specified flow range
- Check that the foam concentrate bladder tank is not empty

The VIP mixing ratio is incorrect:

- Check that the membranes in the pressure balancing valves are intact
- Check for debris in the foam or water line

Contact Incendium if any problems persist.

7. OTHER DOCUMENTATION

All documentation can be found at <http://incendiumfire.com/products/#Proportioning>

Datasheet VIP

Installation Instruction II-0011-VIP-EN